



[HOME](#) / [About the Journal](#)

About the Journal

International Journal of Advanced Multidisciplinary (IJAM) is a scientific journal published by Greenation Publisher under the auspices of the Yayasan Global Resarch National (GREENATION). This journal is published 4 times a year, namely April, July, October and January.

IJAM is a national, peer reviewed, open access and scientific journal that publishes research papers, review papers, mini reviews, case reports, case studies, short communications, letters, editorials, books, theses, dissertation works, etc., from all Aspects of Science. Once published, articles are available for free online without any restrictions or other subscriptions to researchers and readers worldwide.

CALL FOR REVIEWER

ISSN

e-ISSN:

2829-6192

ISSN 2829-6192



EDITORIAL OFFICE

Jl. Kapt. A. Hasan, Telanaipura Jambi-Indonesia

PUBLISHER

IJAM is published by Greenation Publisher & Yayasan Global Research National

CONTACT INFO

+62 812-1046-7572 (Whatsapp)

<https://greenpub.org>

<https://greenpub.org/IJAM>

Email:

greenation.info@gmail.com

IJAM INDEX



Creation is distributed below [Lisensi Creative Commons Atribusi 4.0 Internasional](#).

[View My Stats](#)



[HOME](#) / Editorial Team

Editorial Team

Editor In Chief

[M. Havidz Aima](#), (Id Scopus: [57195481026](#)), Universitas Mercu Buana, Jakarta, Indonesia

Managing Editor

[Andri Yandi](#), Universitas Batanghari, Jambi, Indonesia

Associate Managing Editor

[Christina Catur Widayati](#), Universitas Mercu Buana, Jakarta, Indonesia

Editorial Board

[Hajah Mas Nooraini binti Haji Mohiddin](#), Universiti Islam Sultan Sharif Ali, Brunei Darussalam

[Jamaludin Badusah](#), Universiti Kebangsaan Malaysia, Malaysia

[Chen Si](#), Zhejiang University of Technology, Hangzhou, China

[Mike Tan](#), Deakin University, Geelong, Australia

[Sharmili Mohamed Rafi](#), Dinasti Publisher Group, Malaysia

[Syafri Mulyadi](#), Dinasti Publisher Group, Singapore

[Afi Parnawi](#), Sekolah Tinggi Agama Islam (STAI) Ibnu Sina Batam, Indonesia

[Rita Rahayu](#), Universitas Andalas, Padang, Indonesia

[Ni Komang Mela Tri Utari](#), Universitas Tabanan, Indonesia

[Ebit Bimas Saputra](#), Universitas Ekasakti, Padang, Indonesia

[Dadang Saepuloh](#), Universitas Islam Syekh Yusuf, Tangerang, Indonesia

[Sonny Indrajaya](#), Universitas Mercu Buana, Jakarta, Indonesia

[Dudi Permana](#), Universitas Mercu Buana, Jakarta, Indonesia

[Shinta Amalina Hazrati Havidz](#), Bina Nusantara University, Jakarta Indonesia

[Susi Desmaryani](#), Universitas Muhammadiyah Jambi, Indonesia

[Anastasia Susty Ambarriani](#), Universitas Atma Jaya, Yogyakarta, Indonesia

[Achmad Maqsudi](#), Universitas 17 Agustus 1945, Surabaya, Indonesia

[Josua Panatap Soehaditama](#), Institut Keuangan Perbankan dan Informatika Asia Perbanas, Indonesia

[Heni Pratiwi](#), Universitas Jambi, Jambi, Indonesia

[Hamdy Hady](#), Universitas Persada Indonesia YAI, Jakarta, Indonesia

[Herman Bakir](#), Universitas Borobudur, Jakarta, Indonesia

[Adrian Fadhli](#), Universitas Ekasakti, Padang, Indonesia

[Dian Wahyoni Dewi Fitri](#), Universitas Ekasakti, Padang, Indonesia

[Dian Utami Sutiksno](#), Politeknik Negeri Ambon, Indonesia

[Henny Puspita Sari](#), Universitas Ekasakti, Padang, Indonesia

[Alchonty Harika Fitri](#), Universitas Dharmas Indonesia, Dharmasraya, Sumatera Barat, Indonesia

[Rauldatul Husni](#), Universitas Dharmas Indonesia, Dharmasraya, Sumatera Barat, Indonesia

[Sri Yuli Ayu Putri](#), Universitas Ekasakti, Padang, Indonesia

[Yulia Syafitri](#), Akademi Akuntansi Indonesia Padang, Indonesia

[Noor Salim](#), Universitas Mercu Buana, Jakarta, Indonesia

[Dede Suleman](#), Universitas Pembangunan Jaya, South Tangerang, Indonesia

[Rangga Prayitno](#), Universitas Ekasakti, Padang, Indonesia

[Bisma Putra Pratama](#), Universitas Ekasakti, Padang, Indonesia

[Suyitno](#), Universitas Muhammadiyah Purworejo, Indonesia

[Tina Yuli Fatmawati](#), Sekolah Tinggi Ilmu Kesehatan Baiturrahim, Jambi, Indonesia

[Ansori](#), Institut Agama Islam Nusantara Batanghari

IT Support

[Nofri Satriawan](#), Dinasti Publisher Group, Jakarta, Indonesia



CALL FOR REVIEWER

ISSN

e-ISSN:

2829-6192

ISSN 2829-6192



p-ISSN:

2829-6184

EDITORIAL OFFICE

Jl. Kapt. A. Hasan, Telanaipura Jambi-Indonesia

PUBLISHER

IJAM is published by Greenation Publisher & Yayasan Global Research National

CONTACT INFO

+62 812-1046-7572 (Whatsapp)

<https://greenpub.org>

<https://greenpub.org/IJAM>

Email:

greenation.info@gmail.com

IJAM INDEX



Creation is distributed below [Lisensi Creative Commons Atribusi 4.0 Internasional](#).

[View My Stats](#)



[HOME](#) / [Peer Reviewers](#)

Peer Reviewers

[Leila Chamankhah](#), Thapar Institute of Engineering & Technology, Patiala, India

[Abdelbari El Khamlichi](#), Université Chouaib Doukkali, El Jadida, Morocco

[Gautam Kumar Jha](#), Jawaharlal Nehru University, New Delhi, India

[Minhazur Rahman Rezvi](#), University of Dhaka, Dhaka, Bangladesh

[Kwesi Aning](#), Kofi Annan International Peacekeeping Training Centre (KAIPTC), Accra, Ghana

[Kalu Kingsley Anele](#), Pusan National University, Busan, South Korea

[Yusliza Mohd-Yusoff](#), Universiti Malaysia Terengganu, Malaysia

[Jumadil Saputra](#), Universiti Malaysia Terengganu, Malaysia

[James Thomas Collins](#), Universiti Kebangsaan Malaysia, Bangi, Malaysia

[Ahlam Neamah Latfa](#), Al Qassim University, Buraidah, Saudi Arabia

[Muhammad Anshari](#), Universiti Brunei Darussalam, Bandar Seri Begawan, Brunei Darussalam

[Tomi Kauppinen](#), Aalto University, Espoo, Finland

[Ilhan Tekin Ozturk](#), University of Sharjah, Sharjah, United Arab Emirates

[Viko Ladelta](#), King Abdullah University of Science and Technology, Thuwal, Saudi Arabia

[Mohamed Ally](#), Athabasca University, Canada

[Ubedullah Memon](#), Sukkur IBA University, Sukkur, Pakistan

[Miftachul Huda](#), Universiti Pendidikan Sultan Idris, Tanjong Malim, Malaysia

[Jamalul Lail Abdul Wahab](#), Malaysian National University, Malaysia

[Jamaludin Badusah](#), Universiti Kebangsaan Malaysia, Bangi, Malaysia

[Muhammad Hussin](#), Universiti Kebangsaan Malaysia, Bangi, Malaysia

[Norazah Nordin](#), Malaysian National University, Malaysia

[Norhayati Hashim](#), Universiti Pendidikan Sultan, Tanjong Malim, Malaysia

[Don Eliseo Lucero-Prisno III](#), London School of Hygiene & Tropical Medicine, London, United Kingdom

[Hidayatulfathi Othman](#), Universiti Kebangsaan Malaysia, Bangi, Malaysia

[Prathurng Hongsrnagon](#), Chulalongkorn University, Bangkok, Thailand

[Yandra Rivaldo](#), Institut Agama Islam Abdullah Said Batam, Batam City, Indonesia

[Yayan Hendayana](#), Universitas Islam As-Syafi'iyah, Indonesia

[Suharno Pawirosumarto](#), Universitas Widyatama, Bandung, Indonesia

[Darmansyah](#), Universitas Lampung, Bandar Lampung, Indonesia

[Arissetyanto Nugroho](#), Universitas Pancasila, Jakarta, Indonesia

[Ekawarna](#), Universitas Jambi, Jambi, Indonesia

[Mukhtar](#), UIN Sulthan Thaha Saifuddin Jambi, Indonesia

[Maisah](#), Institut Agama Islam Negeri Sulthan Thaha Saifuddin, Jambi, Indonesia

[Hartati](#), Universitas Jambi, Jambi, Indonesia

[Darmini Roza](#), Universitas Ekasakti, Padang, Indonesia

[Riris Ardhanariswari](#), Universitas Jenderal Soedirman, Indonesia

[Nur Sulistyو Budi Ambarini](#), Universitas Bengkulu, Bengkulu, Indonesia

[Jamin Ginting](#), Universitas Pelita Harapan, Indonesia

[Naik Henokh Parmenas](#), Kalbis Institute, Indonesia

[James Yoseph Palenewen](#), Universitas Cenderawasih, Papua, Indonesia

[Tarma Sartima](#), Universitas Ekasakti, Padang, Indonesia

[Ade Maman Suherman](#), Universitas Jenderal Soedirman, Purwokerto, Indonesia

[Asrinaldi](#), Universitas Andalas, Padang, Indonesia

[Gatut Priowidodo](#), Universitas Petra, Surabaya, Indonesia

[Sugianto](#), PPS UBHARA Jakarta, Jakarta, Indonesia

[Nandan Limakrisna](#), Universitas Persada Indonesia YAI Jakarta, Central Jakarta, Indonesia

[Deden Komar Priatna](#), Winaya Mukti University, Bandung, Indonesia

[Winna Roswinna](#), Winiya Mukti University, Bandung, Indonesia

[Djoko Setyo Widodo](#), Universitas Krisnadwipayana, Bekasi, Indonesia

[Beti Nurbaiti](#), Bhayangkara Jakarta Raya University, Jakarta, Indonesia

[M. Zahari](#), Universitas Batanghari, Jambi, Indonesia

[Sri Mulyono](#), Universitas Islam Sultan Agung Semarang, Semarang, Indonesia

[Muhammad Yusuf](#), Institut Teknologi dan Bisnis Bank Rakyat Indonesia, Jakarta, Indonesia

[Deni Sunaryo](#), Universitas Serang Raya, Serang, Indonesia

[Rumanintya Lisaria Putri](#), Badan Riset dan Inovasi Nasional, Central Jakarta, Indonesia

[Dewi Susita](#), University Negeri Jakarta, Jakarta, Indonesia

[Anik Herminingsih](#), Universitas Mercu Buana, West Jakarta, Indonesia

[Dewi Puspaningtyas Faeni](#), Universitas Bhayangkara Jakarta Raya, Jakarta, Indonesia

[M. Fadhli Nursal](#), Bhayangkara Jakarta Raya University, Jakarta, Indonesia

[M. Prihartono Aksan Halim](#), Politeknik Piksi Ganesha Bandung, Bandung, Indonesia

[Nazili](#), Universitas Ekasakti, Padang, Indonesia

[Irnawati Siregar](#), Universitas Ekasakti, Padang, Indonesia

[Rosnita Rauf](#), Universitas Ekasakti, Padang, Indonesia

[Jasmir](#), Universitas Dinamika Bangsa, Indonesia

[Jujuk Kusumawati](#), Institut Teknologi Budi Utomo, Indonesia

[Nita Yessirita](#), Universitas Ekasakti, Padang, Indonesia

[Ai Komariah](#), Universitas Winaya Mukti, Bandung, Indonesia

[Noertjahyani](#), Universitas Winaya Mukti, Bandung, Indonesia

[Nunung Sondari](#), Universitas Winaya Mukti, Bandung, Indonesia

[I Ketut Budaraga](#), Universitas Ekasakti, Padang, Indonesia

[Wiwik Sulistiani](#), Universitas Hang Tuah, Indonesia

[Dini Wulan Dari](#), Sekolah Tinggi Ilmu Kesehatan Baiturrahim, Jambi, Indonesia

[Dewi Susanna](#), Universitas Indonesia, Depok, Indonesia

[Purnawan Junadi](#), Universitas Indonesia, Depok, Indonesia

[Sandra Fikawati](#), Universitas Indonesia, Depok, Indonesia

[Drupadi HS Dillon](#), Universitas Indonesia, Depok, Indonesia

[Soedjajadi Keman](#), Universitas Airlangga, Surabaya, Indonesia

[Lucky Herawati](#), Health Polytechnic Ministry of Health of Yogyakarta, Yogyakarta, Indonesia

[Irnawati Marsaulina](#), Universitas Sumatera Utara, Medan, Indonesia

[Kholis Ernawati](#), Universitas YARSI, Jakarta, Indonesia

[Ansori](#), Institut Agama Islam Nusantara Batanghari



CALL FOR REVIEWER

<https://greenpub.org/IJAM>

Email:
greenation.info@gmail.com

IJAM INDEX



Creation is distributed below [Lisensi Creative Commons Atribusi 4.0 Internasional](#).

[View My Stats](#)

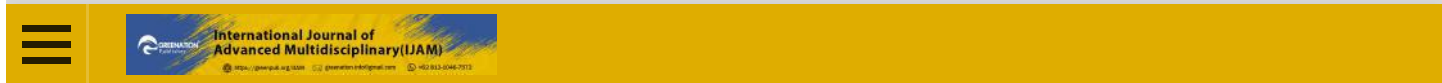

[HOME](#) / [ARCHIVES](#) /

Vol. 3 No. 2 (2024): International Journal of Advanced Multidisciplinary (July-September 2024)

Vol. 3 No. 2 (2024): International Journal of Advanced Multidisciplinary (July-September 2024)



DOI: <https://doi.org/10.38035/ijam.v3i2>

PUBLISHED: 2024-06-30

ARTICLES

Work Life Balance For Lecturers at IAIN Kerinci and Its Impact On Tridharma Productivity

Ahmad Yani, M. Havidz Aima

202-208

 [FULL ARTICLE PDF](#)

Increasing Employee Productivity: Analysis Employee Engagement

Ambar Wariati

209-223

 [FULL ARTICLE PDF](#)

Design of an Efficiency Power Load Control Device on Production Machines with SCADA Basen on Programmable Logic Controller and Smartphone

Edy Supriyadi, Abdul Multi, Iriandi Ilyas, Anthony Jayanto Ramadhan

224-235

 **FULL ARTICLE PDF**

Marketing of Management: Share Market, Potential Market, Competitor Business and Promotion (Literature Review)

Dian Nur Mastuti, Rintis Eko Widodo, Bambang Wijanarko, Harry Purwoko, Agus Suhendra

236-250

 **FULL ARTICLE PDF**

Z's Privacy Calculus on Using a Second Instagram Account

Andika Lutfi Kurniawan, Syahrul Hidayanto

251-262

 **FULL ARTICLE PDF**

The Influence of Emotional Intelligence on Toxic Behavior in Playing the Online Game Mobile Legends

Ridhia Sabilla Rosyad, Syahrul Hidayanto

263-275

 **FULL ARTICLE PDF**

Political Communication of The General Election Commission and The Election Supervisory Board in Responding to Allegations of Voter Data Leakage

M. Yusuf Samad, Sigit Setiono, Diah Ayu Permatasari, Kukuh Pribadi, Pratama Dahlian Persadha

276-283

 **FULL ARTICLE PDF**

Determinants of Occupational Stress in Health Services: Analysis of Communication Skills and Work Units (A Literature Review)

Muhammad Dwi Satriyanto, Ratna Wardani

284-291

 **FULL ARTICLE PDF**

Strategies for Creating Quality Managers Through Talent Management, Job Enrichment and Assessment

Reza Fauzi Jaya Sakti, Peppy Fachrial, Maludin Panjaitan, Hartini Hartini, Siti Normi

292-303

<https://greenpub.org/IJAM>

Email:
greenation.info@gmail.com

IJAM INDEX



Creation is distributed below [Lisensi Creative Commons Atribusi 4.0 Internasional](#).

[View My Stats](#)



[HOME](#) / [ARCHIVES](#) /

[VOL. 3 NO. 2 \(2024\): INTERNATIONAL JOURNAL OF ADVANCED MULTIDISCIPLINARY \(JULY-SEPTEMBER 2024\)](#)

/

[Articles](#)

Design of an Efficiency Power Load Control Device on Production Machines with SCADA Basen on Programmable Logic Controller and Smartphone

Edy Supriyadi

Institut Sains Dan Teknologi Nasional, Jakarta, Indonesia

Abdul Multi

Institut Sains Dan Teknologi Nasional, Jakarta, Indonesia

Iriandi Ilyas

Institut Sains Dan Teknologi Nasional, Jakarta, Indonesia

Anthony Jayanto Ramadhan

Institut Sains Dan Teknologi Nasional, Jakarta, Indonesia

DOI: <https://doi.org/10.38035/ijam.v3i2.566>

Keywords: PLC Control, Android, Mobile HMI, WiFi, SCADA

ABSTRACT

With limited electrical resources and the increasing use of loads on the industry, it is required to optimize the use of electrical power. Thus, it requires continuous monitoring and automatic load control. Overall monitoring of power loads, and electrical control settings in the optimization of production machines that can be monitored remotely and comprehensively. To overcome this problem, the design of the electrical power load control device on production machines with scada based on programmable logic controllers and smartphones is made. This study uses an experimental method to obtain a suitable machine simulator, then the following steps are carried out: collecting data and information, determining the controller and communication system,

making hardware design, wiring simulator, software controller design, android smartphone software design and HMI software design. As for the control of the electric power control system in optimizing the operation of production machines with scada and smartphones. From the test results obtained a system that can work well. This is evidenced by looking at the measurement data for testing the input/output signal from the controller by looking directly at the controller, as well as on the HMI monitor by displaying the amount of electrical power used and the amount of available electrical resources, which is done by simulating analog input/output. with a scale of 0-100% (0-10 V), 0-1000 KW (0-10 V).

REFERENCES

Sardi Salim, Ade Irawaty Tolago, Maharani R.P. Syafi'I, (2022). Analisis Intensitas Konsumsi Energi Listrik Untuk Penghematan Listrik Di Fakultas Teknik UNG, Jurnal Nasional Teknik Elektro dan Teknologi Informasi | Vol. 11, No. 1, Februari 2022, p-ISSN: 2301 – 4156, e-ISSN : 2460 –5719.

Dini Mulyani, Djoni Hartono, (2018) Pengaruh Efisiensi Energi Listrik pada Sektor Industri dan Komersial terhadap Permintaan Listrik di Indonesia, Jurnal Ekonomi Kuantitatif Terapan Vol. 11 No.1 Februari 2018, p-ISSN : 2301 – 8968, e-ISSN : 2303 – 0186.

Abrar Tanjung, Zulfahri, Hamzah, David Setiawan, (2020), Penerapan Sistem Pengamanan Instalasi Listrik di Kecamatan Rumbai Pesisir, Jurnal Pengabdian Kepada Masyarakat e-ISSN: 2774-9800 Vol. 1, No. 2, Oktober 2020, Hal. 53-60.

Suhanto, (2017), Section Articles Rancang Bangun Simulasi Supervisory Control And Data Acquisition (SCADA) Main Distribution Panel (MDP) Berbasis Programmable Logic Controller (PLC), Vol. 2 No. 1 (2017): Jurnal Penelitian Maret 2017, <https://doi.org/10.46491/jp.v2i1.111>,

Ditjeng Marsudi, (2006). Operasi system Tenaga Listrik. Edisi Pertama. Graha Ilmu. Yogyakarta

Setiawan, A. B. (2016). Jurnal Penelitian Pos dan Informatika Peningkatan Keamanan Supervisory Control And Data Acquisition (Scada) Pada Smart Grid Sebagai Infrastruktur Kritis Improved Security Supervisory Control And Data Acquisition (Scada) The Smart Grid As Critical Infrastructure, 6(1). <https://doi.org/10.17933/jppi>.

Sitohang, E. P., Mamahit, D. J., Tulung, N. S., Elektro, T., Sam, U., Manado, R., & Manado, J. K. B. (2018). Rancang Bangun Catu Daya DC Menggunakan Mikrokontroler ATmega 8535, 7(2), 135–142.

Sridianti (2018). Apa pengertian smartphone dan sejarah [online], (<http://www.sridianti.com/apa-pengertian-smartphone-dan-sejarah.html>), diakses pada 2 agustus 2020).

Dewi, T. K., Sasmoko, P., Teknik, F., & Diponegoro, U. (2014). Aplikasi Programmable Logic Controller (PLC) Omron CPLE Na20 Dra Dalam Proses Pengaturan Sistem Kerja Transformator Penyearah Penapis Peregulasi Penguat Arus DC, 17(4), 170–177.

Dihan, F. N. (2010). Smartphone: Antara Kebutuhan Dan E-Lifestyle. Smartphone: Antara Kebutuhan Dan E-Lifestyle, 1(semnasIF), E-315.

Mohamad Nazir Ph D (2011), Metode Penelitian.

E-ISSN : 2829-6192

P-ISSN : 2829-6184

Volume 3, Issue 2, July 2024

International Journal of Advanced Multidisciplinary (IJAM)



<https://greenpub.org/index.php/IJAM>

 FULL ARTICLE PDF

PUBLISHED

2024-07-15

HOW TO CITE

Supriyadi, E., Multi, A., Ilyas, I., & Jayanto Ramadhan, A. (2024). Design of an Efficiency Power Load Control Device on Production Machines with SCADA Basen on Programmable Logic Controller and Smartphone. *International Journal of Advanced Multidisciplinary*, 3(2), 224–235. <https://doi.org/10.38035/ijam.v3i2.566>

More Citation Formats 

ISSUE

[Vol. 3 No. 2 \(2024\): International Journal of Advanced Multidisciplinary \(July-September 2024\)](#)

SECTION

Articles

LICENSE

Copyright (c) 2024 Edy Supriyadi, Abdul Multi, Iriandi Ilyas, Anthony Jayanto Ramadhan



This work is licensed under a [Creative Commons Attribution 4.0 International License](#).

Authors who publish their manuscripts in this journal agree to the following conditions:

1. The copyright on each article belongs to the author(s).
2. The author acknowledges that the International Journal of Advanced Multidisciplinary (IJAM) has the right to be the first to publish with a [Creative Commons Attribution 4.0 International license](#) (Attribution 4.0 International (CC BY 4.0)).
3. Authors can submit articles separately, arrange for the non-exclusive distribution of manuscripts that have been published in this journal into other versions (e.g., sent to the author's institutional repository, publication into books, etc.), by acknowledging that the manuscript has been published for the first time in the International Journal of Advanced Multidisciplinary (IJAM).

<https://greenpub.org/IJAM>

Email:
greenation.info@gmail.com

IJAM INDEX



Creation is distributed below [Lisensi Creative Commons Atribusi 4.0 Internasional](#).

[View My Stats](#)

DOI: <https://doi.org/10.38035/ijam.v3i2>Received: June 21st, 2024, Revised: June 28th, 2024, Publish: July 15th, 2024<https://creativecommons.org/licenses/by/4.0/>

Design of an Efficiency Power Load Control Device on Production Machines with SCADA Basen on Programmable Logic Controller and Smartphone

Edy Supriyadi¹, Abdul Multi², Iriandi Ilyas³, Anthony Jayanto Ramadhan⁴¹Institut Sains Dan Teknologi Nasional, Jakarta, Indonesia, e-mail: edy_syadi@istn.ac.id²Institut Sains Dan Teknologi Nasional, Jakarta, Indonesia, e-mail: amulti@istn.ac.id³Institut Sains Dan Teknologi Nasional, Jakarta, Indonesia, e-mail: iriandi@istn.ac.id⁴Institut Sains Dan Teknologi Nasional, Jakarta, Indonesia, e-mail: anthonyj.ramadhan@gmail.comCorresponding Author: edy_syadi@istn.ac.id¹

Abstract: With limited electrical resources and the increasing use of loads on the industry, it is required to optimize the use of electrical power. Thus, it requires continuous monitoring and automatic load control. Overall monitoring of power loads, and electrical control settings in the optimization of production machines that can be monitored remotely and comprehensively. To overcome this problem, the design of the electrical power load control device on production machines with scada based on programmable logic controllers and smartphones is made. This study uses an experimental method to obtain a suitable machine simulator, then the following steps are carried out: collecting data and information, determining the controller and communication system, making hardware design, wiring simulator, software controller design, android smartphone software design and HMI software design. As for the control of the electric power control system in optimizing the operation of production machines with scada and smartphones. From the test results obtained a system that can work well. This is evidenced by looking at the measurement data for testing the input/output signal from the controller by looking directly at the controller, as well as on the HMI monitor by displaying the amount of electrical power used and the amount of available electrical resources, which is done by simulating analog input/output. with a scale of 0-100% (0-10 V), 0-1000 KW (0-10 V).

Keyword: PLC Control, Android, Mobile HMI, WiFi, SCADA

INTRODUCTION

In development, infant incubators can use IoT for access control and monitoring. Internet of Things is a concept where everyday objects or devices are connected and communicate with each other through the Internet network (Nurfajar Muslim, 2017).

Based on the existing problems, development is needed in the infant incubator so that it can reduce the death rate in infants caused by tilt and vibration that occurs during transfer, and can be monitored in real-time by other parameters so that the baby's condition is maintained. (Laurence Blaxter, 2017).

The use of electric power is very much, both the use in homes, offices and especially the use of industrial electric power (Sardi Salim, 2022). Electronic technology nowadays all household and industrial equipment mostly uses electricity (Dini Mulyani, 2018). With limited electrical resources and increasing load usage, it is required to optimize the use of electrical power, to prevent overloading which results in other losses (Abrar Tanjung, 2020). With the number of loads that are increasing along with the needs of the required users of electricity maximally and efficiently. due to limited existing sources of electricity. Maximum use of the load in accordance with the available resources and efficient no excess resources available (Ditjeng Marsudi, 2006). To control the maximum use of power requires continuous monitoring and automatic load control is not controlled by an operator (Ditjeng Marsudi, 2006).It takes monitoring of the entire power load, therefore a system is needed to be able to regulate electrical control in the optimization of production machinery and can be monitored remotely and thoroughly (Ditjeng Marsudi, 2006). With the use of an integrated control system and an automatic control system with easy monitoring, it will reduce production losses and more importantly reduce the level of work accidents, because the load control process is carried out automatically, not carried out by the operator directly (Ditjeng Marsudi, 2006).

METHOD

This research was conducted to obtain a reliable machine control continuously with high control accuracy, which is supported by the ease of monitoring and controlling the machine itself. By using an integrated control programme and an accurate interface (HMI) and easy access to monitor the activities of the control system for the use of electric power with automatic for operational production machines with animation control and remote monitor remotely using scada and android smartphone.

Creating an automatic electric power usage control system for production machine operations with animated controls and remote monitors using scada and android smartphones. in homes, offices and especially the use of industrial electric power.

Research methods can be categorised into five general groups, as follows;

1. Historical methods
2. Descriptive/survey methods
3. Experimental method
4. Grounded research method
5. Action research method.

As described in the book Research Methods (Moh.Nazir, Ph.D, 2011; 47).

Research methods specifically here the author uses 2 research methods, namely experimental methods to get the most suitable engine simulator and descriptive methods to be able to make descriptions, systematic, factual and accurate descriptions of the facts, properties and relationships between the phenomena being investigated, by directly observing and analysing existing data both field data and data from other sources.

Planning Hardware

Hardware design in the Design of Electrical Power Load Control System in Production Machine Automation with PLC and Smartphone Based Scada, is a simulator tool to simulate electrical power settings automatically adjusted between loads and available electrical resources. The settings here will automatically function if there is a change in the power source due to a certain disturbance so as not to interfere with the supply of power to the load or electric power that will be distributed to the selected load according to a predetermined priority, for more details can be seen in Figure 1.

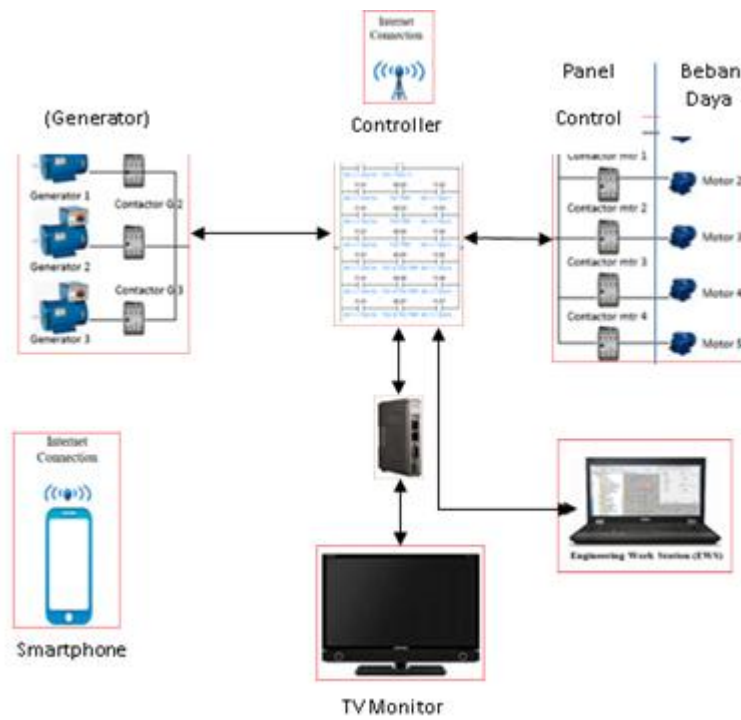

Figure 1. Network design of Power Control System

From Figure 1, there are 3 sources of electrical power with an automatic setting system that can be determined and select chapters that are prioritised according to needs.

For the design of this automatic power regulator system using a Programmable logic controller (PLC) while for display (display) using a TV monitor or computer.

The design of this Programmable Logic Control (PLC) Based Automatic Power Regulator system using several communication systems can be seen in Figure 2.

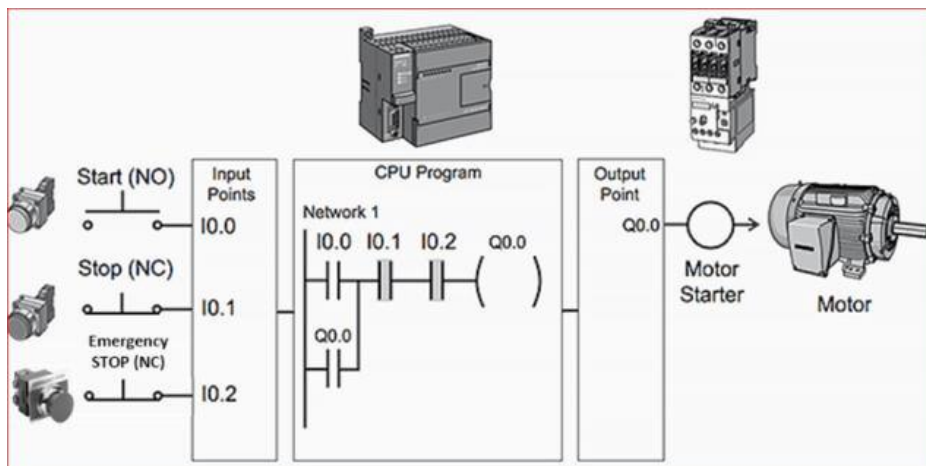

Figure 2. Input Output Communication on PLCs

In Figure 2, designed for all switches as input data to the controller through Digital input, while for current reading data or the amount of electrical power load data used, input data through analogue input. To control the power load or turn off and activate the power load as well as for electrical power sources, digital output is used, where the digital output drives the relay output and the relay will drive the motor control on the control panel.

As for controlling the power source and power load on the logic control on the controller, the Controller will read the status of the source and the number of active electric power loads to run the logic that has been made and stored on the controller.

Planning Software

The software design here consists of a programme for the operation of the PLC and a programme for the display of animation or indications of the processes occurring in the PLC. Programming on the PLC is in the form of Leader diagrams, while for programming on indications in the form of animated images connected to the address of the program on the PLC, so that there is a change in the shape of the image display according to the conditions in the PLC program.

RESULT AND DISCUSSION

Hardware Result and Discussion

Testing a 24 Volt Dc Power Supply with a capacity of 2 Amperes, there is a decrease in voltage and an increase in temperature in the power supply unit.

Power supply is a source of power to operate the equipment used. After measuring and summing up the required power, it turns out that a voltage of 24 volts is needed with a current of more than 2 amperes. After replacing the power supply with a maximum capacity of 5 Amperes, all systems operate normally.



(a)



(b)

Figure 7. Power Supply (PS) 24 Volt DC and PS 24 V 5 A

Ethernet-based communication between PLC Omron CP1L and HMI module MTV-100 cannot be done, with the condition that the communication cable is well connected. Communication system between the Omron CP1L PLC using the Ethernet communication system, using the CP1W module and the RG45 connection cable connected to the HUB with the HMI module MTv connected to the HUB, as shown in Figure 5. At that time the indicator light on the CP1W PLC communication module with the condition off as in Figure 6.

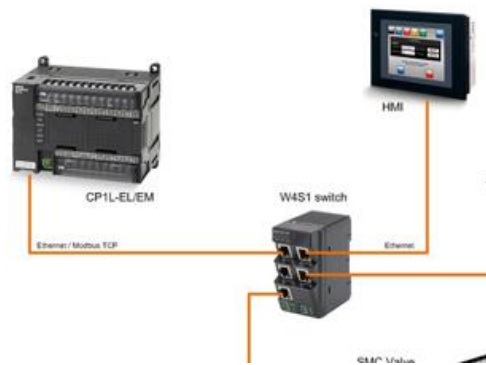

Figure 5. Communication cable connection between Omron CP1L PLC and MTV via HUB



Figure 6. Indicator CP1W is not connected between PLC and HMI

When communication between the PLC and the HMI module cannot be done, the EWS is used as an auxiliary tool, and looks directly at the indicator light on the CP1W module and the indicator light on the HUB where the channel used looks dead or flashing. The findings obtained by the condition of the indicator light on the PLC communication module is dead, it can be estimated that there is a problem with the PLC communication module, because the PLC is still operating normally.

To prove it, EWS is used as a tool to detect cracks. By using the EWS and Ethernet cable communication connected to the HUB and using the “Command Prompt” application to access the IP address of the PLC CP1W communication module as shown in Figure 7. The results of checking by accessing the IP address as above, obtained data as in Figure 8.

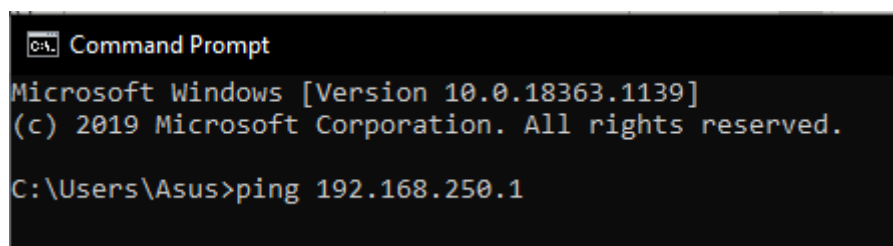

Figure 7. Command Prompt application to access IP address 192.168.250.1

```
Command Prompt
Microsoft Windows [Version 10.0.18363.1139]
(c) 2019 Microsoft Corporation. All rights reserved.

C:\Users\Asus>ping 192.168.250.1

Pinging 192.168.250.1 with 32 bytes of data:
Request timed out.
Request timed out.
Request timed out.
Request timed out.

Ping statistics for 192.168.250.1:
    Packets: Sent = 4, Received = 0, Lost = 4 (100% loss),
```

Figure 8. The result of checking IP Address 192.168.250.1 is not connected

Thus it can be confirmed that the CP1W PLC communication module is not working. To fix this by cleaning the connection socket as a communication link or replacing it with a new one. Then we check the hardware by removing the CP1W communication module from the PLC and cleaning the connection socket and reinstalling it then we recheck using the “Command Prompt” application and succeed as in Figure 9.

It can also be seen that the indicator contained in the CP1W module is blinking indicating that it is connected can be seen in Figure 10.

```
Command Prompt
Microsoft Windows [Version 10.0.18363.1139]
(c) 2019 Microsoft Corporation. All rights reserved.

C:\Users\Asus>ping 192.168.250.1

Pinging 192.168.250.1 with 32 bytes of data:
Reply from 192.168.250.1: bytes=32 time=4ms TTL=64
Reply from 192.168.250.1: bytes=32 time=3ms TTL=64
Reply from 192.168.250.1: bytes=32 time=2ms TTL=64
Reply from 192.168.250.1: bytes=32 time=2ms TTL=64

Ping statistics for 192.168.250.1:
    Packets: Sent = 4, Received = 4, Lost = 0 (0% loss),
    Approximate round trip times in milli-seconds:
        Minimum = 2ms, Maximum = 4ms, Average = 2ms
```

Figure 9. The results of checking IP Address 192.168.250.1 can be connected after repairing the module



Figure 10. Indicator CP1W is already connected between PLC and HMI

In addition, an indication of whether or not the PLC is connected to the HMI can be seen on the HMI display when in RUN if there is a PLC no response indication, it is certain that the PLC is not connected to the HMI, can be seen in Figure 11.



Figure 11. HMI display indicator that is not connected to the PLC

However, if there is no PLC no response indication, it is certain that the PLC is connected to the HMI, as can be seen in Figure 12.

Wifi-based remote communication between PLC and EWS cannot be done. Between PLC and EWS communication can be with two types of communication, namely with an Ethernet network via a HUB or by using a Wifi remote system via a Router device. When testing remote communication and it turns out that it cannot be done, there are several possibilities that cause it, including; connecting cable between PLC and HUB or HUB with Router, damage to the HUB, damage to the PLC communication module.



Figure 12. HMI display when connected to PLC

To analyze it can be seen from the indicator light on the communication module on the PLC, the indicator on the channel of the HUB used and the indicator on the Ethernet port of the EWS used. In addition, you can check the IP address used between the PLC device and the computer that functions as an EWS by pinging the IP address of the PLC and EWS at the command prompt.

After checking several possibilities above, it was found that the same IP address number was used between PLC and EWS. After resetting; PLC IP address 192.168.250.1 and EWS IP address is set automatically (DHCP), communication between PLC and EWS can be done, for more details can be seen in Figure 13.

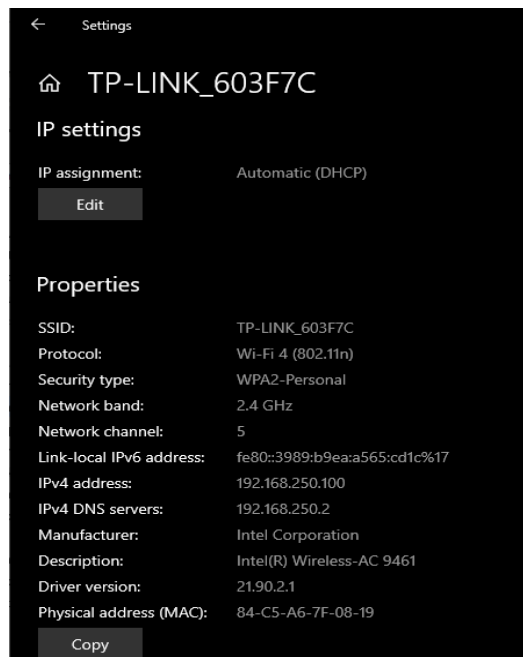

Figure 13. The result of checking IP Address 192.168.250.

Software Results and Discussion

Programming automatic power load selection so that it can automatically determine the load that is maintained according to the selection. The Omron CP1L PLC program design uses the CX Programmer software application with the programming according to Figure 14. By defining the possible status that will occur when there is a change in the status of the electrical power source, in this case consisting of 3 power sources; Generator-1, Generator-2, and Generator-3.

With 7 possibilities available namely; 1) All three generators with Run condition, 2) Generator-1 Stop and two other Generators Stop, 3) Generator-2 Stop and two other generators Run, 4) Generator-3 Stop and two other generators Run, 5) Generator-3 Run and two other Generators Stop, 6) Generator-2 Run and two other Generators Stop, 7) Generator-1 Run and the other two Generators Stop.

The status of the generators is compared with the input from the HMI for load selection if any of the 7 possibilities occur. For example, if Motor-1 will be kept running when Generator-1 stops. So by making a selection on the HMI the data is used for selection in the event of a generator-1 Stop. Likewise for the five simulator motors, can be seen in Figure 15.

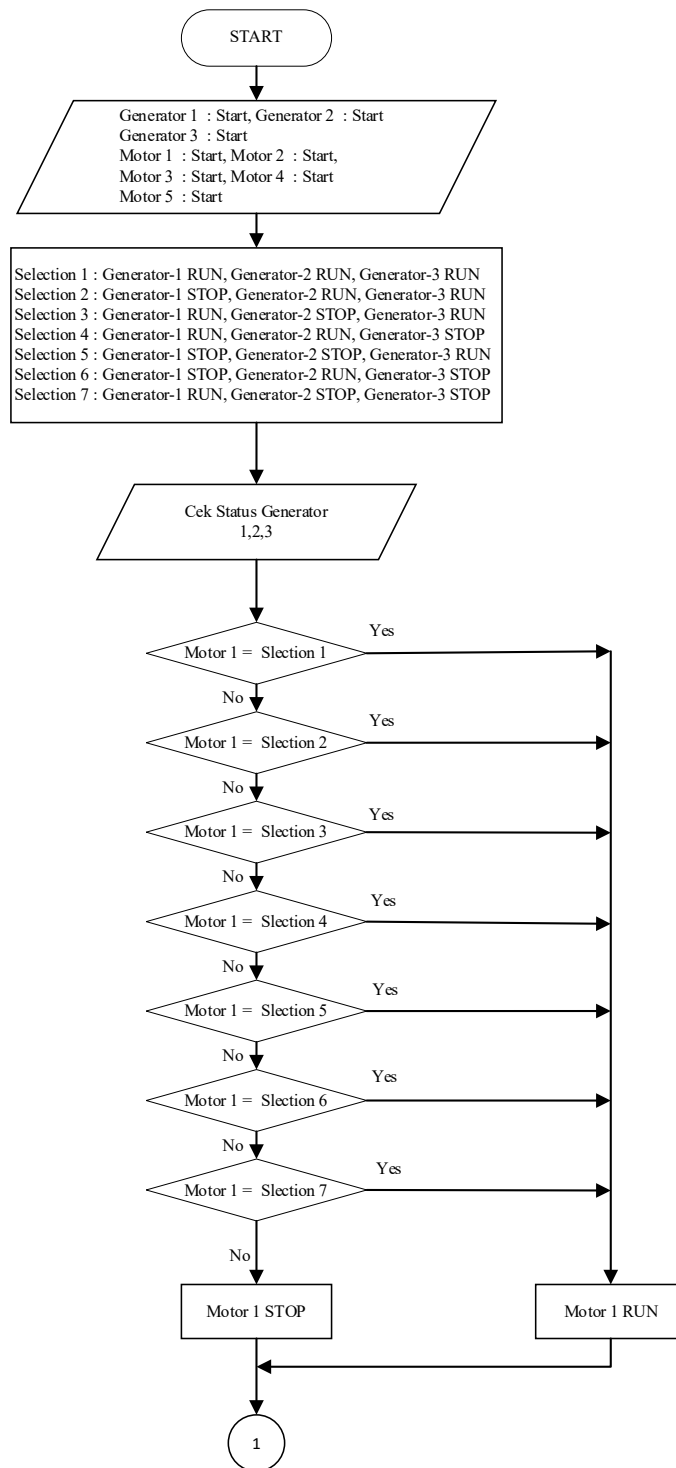

Figure 13. Flow chart diagram and logic program, for Motor-1.

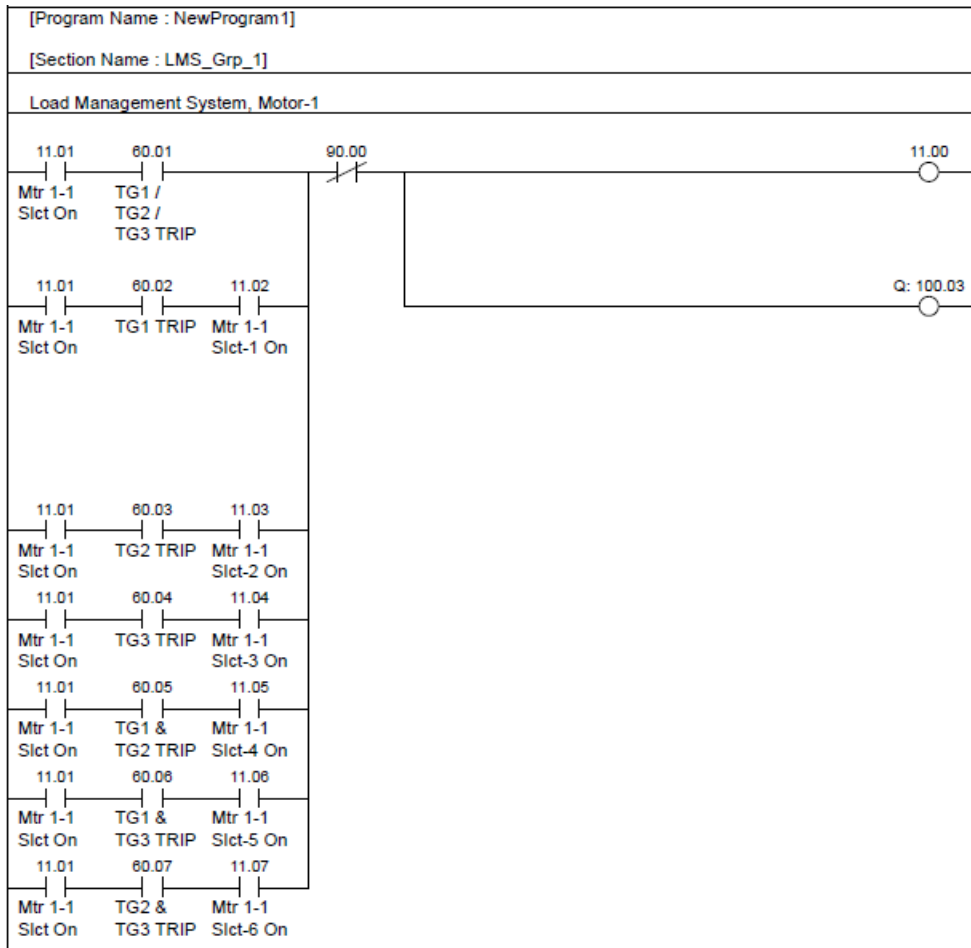

Figure 14. Leader Diagram PLC Program, for Motor-1



Figure 15. Load selection HMI display motor 1 priority

To be able to monitor the power distribution control process anywhere and based on internet communication, the Chrome Remote Desktop android application is used. By accessing the EWS online through the Chrome Remote Desktop application, through the Chrome Remote Desktop application, the animated graphic display of the Desktop sharing process can be accessed and controlled by EWS, you can see the online status of the ongoing power and control to turn on and off the tool remotely. The display when the Smartphone is connected to the EWS can be seen in Figure 16.



Figure 16. Display when EWS is connected to Smartphone via Chrome Remote Desktop

The system built is limited to a simulator of the selection of three electric power sources and a simulator of five electric motors as a load of listrik power, due to the limitations of existing tools. For the manufacture of this system, it is recommended to use a controller, which can use PLC, DCS or other controllers that are standard for industrial control. This system can be applied in industry, office buildings, or housing that uses large resources and a large number of loads, so that the use of electric power can be controlled efficiently by prioritizing according to the function and safety of existing load equipment. In this design can be developed by using a PLC that has more I / O to be able to control more power, as well as developing applications to be used with various operating systems on mobile phones and optimizing the network can be reached more widely. This design can be developed using AI (Artificial Intelligence) artificial intelligence technology that can analyze problems that have occurred to be analyzed and can control when different problems occur in the future.

CONCLUSION

From the results of the design of this tool to the findings and discussion, the following conclusions can be drawn:

1. The design of Electric Power Control Tools on Production Machines with Scada Based on Programmable Logic Control (PLC) and Smartphones can be realized with a simulator of the amount of power from the power source and the amount of load used. The design of Electric Power Control Tools on Production Machines with Scada Based on Programmable Logic Control (PLC) and Smartphones can be realized with a simulator of the amount of power from the power source and the amount of load used.
2. Maximum and efficient use of electricity with limited sources of electrical energy that can be achieved in an automatic way, the system will regulate the operation of the load adjusted to the amount of available resources, so as to make the electrical energy power regulation system more controlled with high reliability and precision.
3. Monitoring electrical energy power settings to make it easier and more optimal by using a smartphone has been realized by means of a smartphone device used for remote monitoring, and is done anywhere easily and practically, but can monitor a large system and can be done anywhere as long as there is an internet network, so that it can make a communication system between the Programmable logic controller (PLC) control with an android application system (chrome remote desktop).
4. The communication tool between the Programmable logic controller (PLC) control and the Android application system (chrome remote desktop) can be realized using a smartphone using a third party application (chrome remote desktop) which can only be used on Android smartphones and has the possibility of being accessed by the application maker.

REFERENCES

- Sardi Salim, Ade Irawaty Tolago, Maharani R.P. Syafi'I, (2022). Analisis Intensitas Konsumsi Energi Listrik Untuk Penghematan Listrik Di Fakultas Teknik UNG, *Jurnal Nasional Teknik Elektro dan Teknologi Informasi* | Vol. 11, No. 1, Februari 2022, p-ISSN: 2301 – 4156, e-ISSN : 2460 –5719.
- Dini Mulyani, Djoni Hartono, (2018) Pengaruh Efisiensi Energi Listrik pada Sektor Industri dan Komersial terhadap Permintaan Listrik di Indonesia, *Jurnal Ekonomi Kuantitatif Terapan* Vol. 11 No.1 Februari 2018, p-ISSN : 2301 – 8968, e-ISSN : 2303 – 0186.
- Abrar Tanjung, Zulfahri, Hamzah, David Setiawan, (2020), Penerapan Sistem Pengamanan Instalasi Listrik di Kecamatan Rumbai Pesisir, *Jurnal Pengabdian Kepada Masyarakat* e-ISSN: 2774-9800 Vol. 1, No. 2, Oktober 2020, Hal. 53-60.
- Suhanto, (2017), Section Articles Rancang Bangun Simulasi Supervisory Control And Data Acquisition (SCADA) Main Distribution Panel (MDP) Berbasis Programmable Logic Controller (PLC), Vol. 2 No. 1 (2017): *Jurnal Penelitian* Maret 2017, <https://doi.org/10.46491/jp.v2i1.111>,
- Ditjeng Marsudi, (2006). *Operasi system Tenaga Listrik*. Edisi Pertama. Graha Ilmu. Yogyakarta
- Setiawan, A. B. (2016). *Jurnal Penelitian Pos dan Informatika Peningkatan Keamanan Supervisory Control And Data Acquisition (Scada) Pada Smart Grid Sebagai Infrastruktur Kritis Improved Security Supervisory Control And Data Acquisition (Scada) The Smart Grid As Critical Infrastructure*, 6(1). <https://doi.org/10.17933/jppi>.
- Sitohang, E. P., Mamahit, D. J., Tulung, N. S., Elektro, T., Sam, U., Manado, R., & Manado, J. K. B. (2018). Rancang Bangun Catu Daya DC Menggunakan Mikrokontroler ATmega 8535, 7(2), 135–142.
- Sridianti (2018). Apa pengertian smartphone dan sejarah [online], (<http://www.sridianti.com/apa-pengertian-smartphone-dan-sejarah.html>, diakses pada 2 agustus 2020).
- Dewi, T. K., Sasmoko, P., Teknik, F., & Diponegoro, U. (2014). Aplikasi Programmable Logic Controller (PLC) Omron CPLE Na20 Dra Dalam Proses Pengaturan Sistem Kerja Transformator Penyearah Penapis Peregulasi Penguat Arus DC, 17(4), 170–177.
- Dihan, F. N. (2010). Smartphone: Antara Kebutuhan Dan E-Lifestyle. *Smartphone: Antara Kebutuhan Dan E-Lifestyle*, 1(semnasIF), E-315.
- Mohamad Nazir Ph D (2011), *Metode Penelitian*.