



BERITA ACARA PERKULIAHAN
(PRESENTASI KEHADIRAN DOSEN)
SEMESTER GANJIL TAHUN AKADEMIK 2020/2021
PROGRAM STUDI TEKNIK MESIN S.1 -ISTN

Mata Kuliah	: Menggambar Mesin 1	Semester	: I
Dosen	: Ir. Rudi Saputra, MT	SKS	: 2
Hari	: Senin	Kelas	: A
Jam	: 15.00-16.00	Ruang	: Online

No.	TANGGAL	MATERI KULIAH	JML MHS HADIR	TANDA TANGAN DOSEN
1.	14 Sept 20	Pendahuluan	7	
2.	21 Sept 20	Peralatan Gambar	7	
3.	28 Sept 20	Ukuran Kertas dan Papan Nama	7	
4.	05 Okt 20	Macam-macam Garis	7	
5.	12 Okt 20	Huruf dan Angka	7	
6.	19 Okt 20	Proyeksi Amerika	7	
7.	26 Okt 20	Proyeksi Eropa	7	
8.	02 Nov 20	UJIAN TENGAH SEMESTER (26 Okt-07 Nov 2020)		

DOSEN PENGAJAR

(Ir. Rudi Saputra, MT)



BERITA ACARA PERKULIAHAN
(PRESENTASI KEHADIRAN DOSEN)
SEMESTER GANJIL TAHUN AKADEMIK 2020/2021
PROGRAM STUDI TEKNIK MESIN S.1 -ISTN

Mata Kuliah	: Menggambar Mesin 1	Semester	: I
Dosen	: Ir. Rudi Saputra, MT	SKS	: 2
Hari	: Senin	Kelas	: A
Jam	: 15.00-16.00	Ruang	: Online

No.	TANGGAL	MATERI KULIAH	JML MHS HADIR	TANDA TANGAN DOSEN
9.	16 Nov 20	Teknik Pengukuran	7	
10.	23 Nov 20	Isometri	7	
11.	30 Nov 20	Konstruksi Geometris	7	
12.	07 Des 20	Potongan/Irisan (Bag. Pertama)	7	
13.	14 Des 20	Potongan/Irisan (Bag. Kedua)	7	
14.	21 Des 20	Mur dan Baut (Bag. Pertama)	7	
15.	28 Des 20	Mur dan Baut (Bag. Kedua)	7	
16.	25 Jan 21	UJIAN AKHIR SEMESTER (18-30 Januari 2021)		

Mengetahui
Kepala Program Studi Teknik Mesin

(Ir. Ucok Mulyo Sugeng, MT)

DOSEN PENGAJAR

(Ir. Rudi Saputra, MT)

DAFTAR HADIR
UJIAN AKHIR SEMESTER
SEMESTER GANJIL TAHUN AKADEMIK 2020/2021

Program Studi	: Teknik Mesin S-1, Reguler, Kls (A), FTI-ISTN
Mata Kuliah	: Menggambar Mesin 1
Hari/Tanggal	: Senin, 25 Januari 2021
Jam	: 15.00-16.40 WIB
Ruang	: Virtual (Online)
Sifat Ujian	: Take Home Test
Dosen	: Ir. Rudi Saputra, MT

NO	NAMA LENGKAP	NIM	HADIR/TIDAK HADIR
1.	Mochamad Ichsan	16210001	Tidak Hadir
2.	Bayu Nur Prasetyo	16210016	Hadir
3.	Andi Julianto	20210001	Hadir
4.	Hafizh Adiya Pratama	20210002	Hadir
5.	Ahmad Zakly Annawawi	20210003	Tidak Hadir
6.	E. Rayhan Danang Oktavian	20210004	Tidak Hadir
7.	Tedy Kusuma Putra	20210005	Hadir

Jakarta, 25 Januari 2021
DOSEN PENGAJAR



(Ir. Rudi Saputra, MT)

PERALATAN MENGGAMBAR

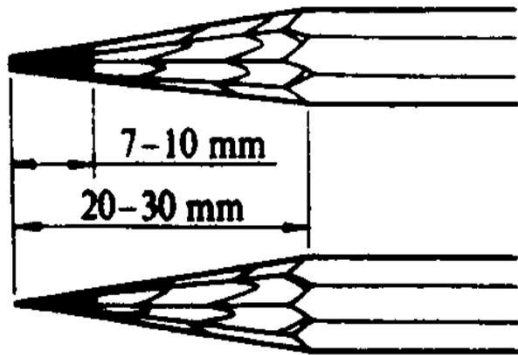

(a) Baji

(b) Tirus

Gb. 3.1 Bentuk ujung potlot.

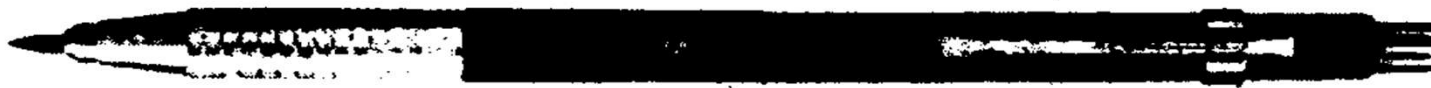

(a)



(b)

Gb. 3.2 Potlot gambar yang dapat diisi kembali dan potlot mekanis.

PERALATAN MENGGAMBAR

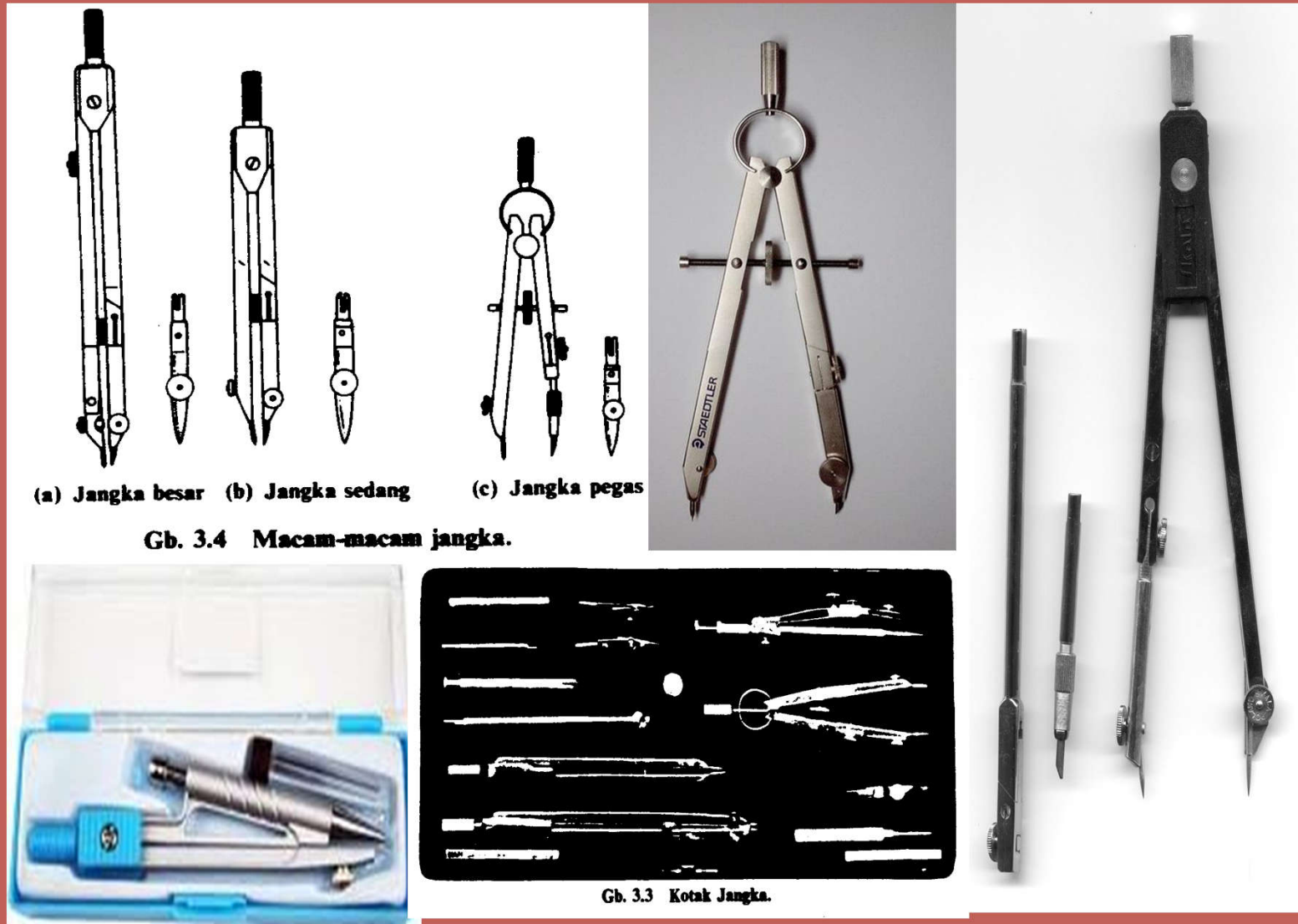

PERALATAN MENGGAMBAR

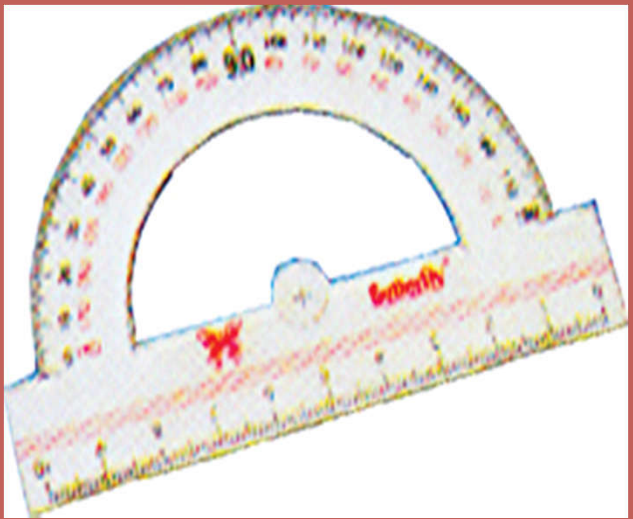
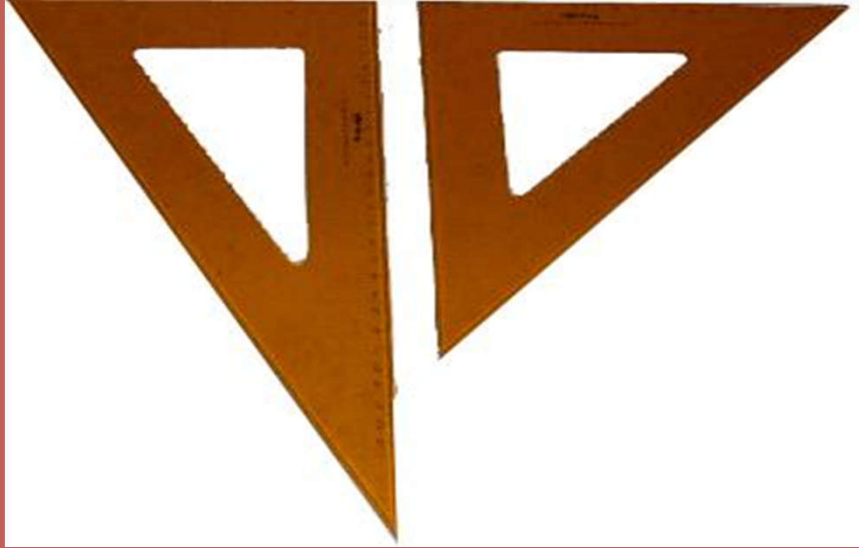
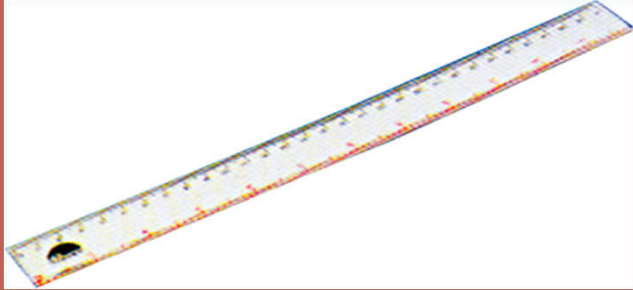

PERALATAN MENGGAMBAR

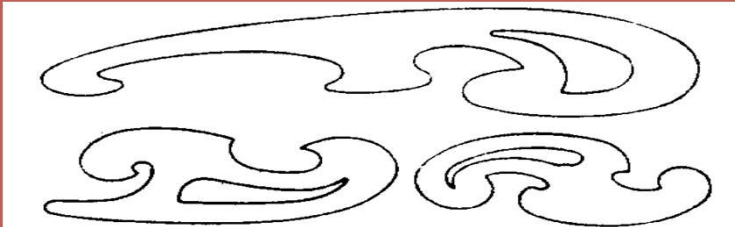

Gb. 3.9 Mal lengkungan.

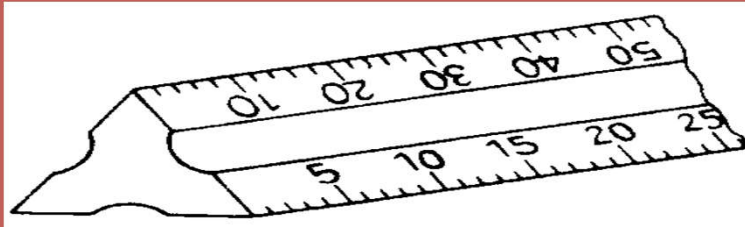

Gb. 3.11 Mistar skala.

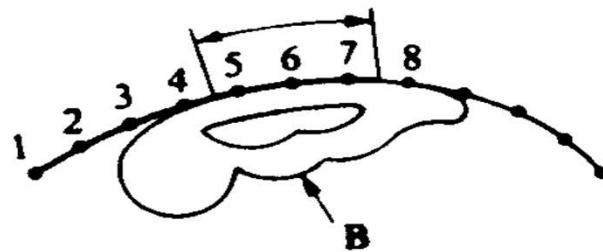
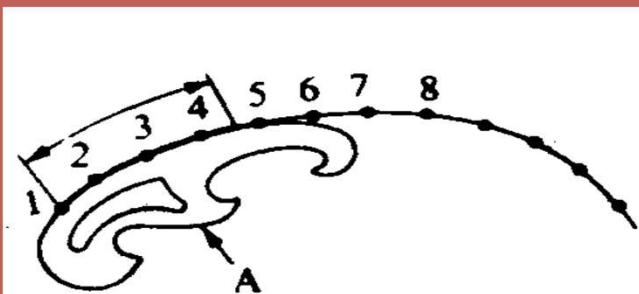

Gb. 3.27 Penggunaan mal.

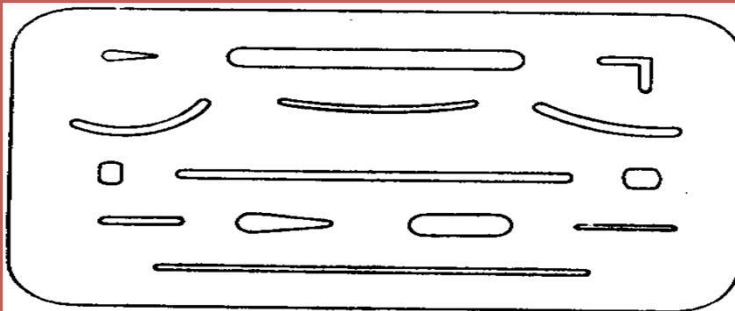

Gb. 3.13 Pelindung penghapus.

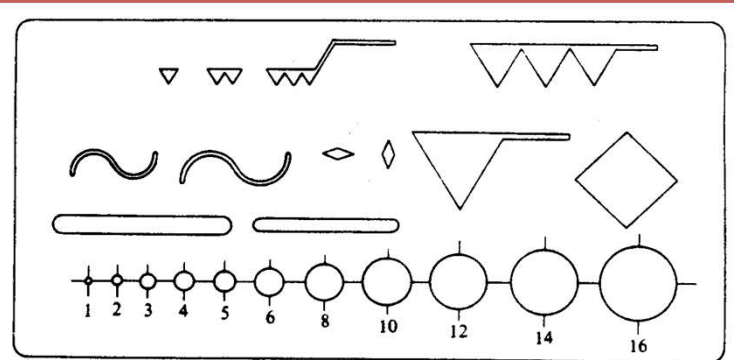

Gb. 3.10 Sablon bentuk.

PERALATAN MENGGAMBAR

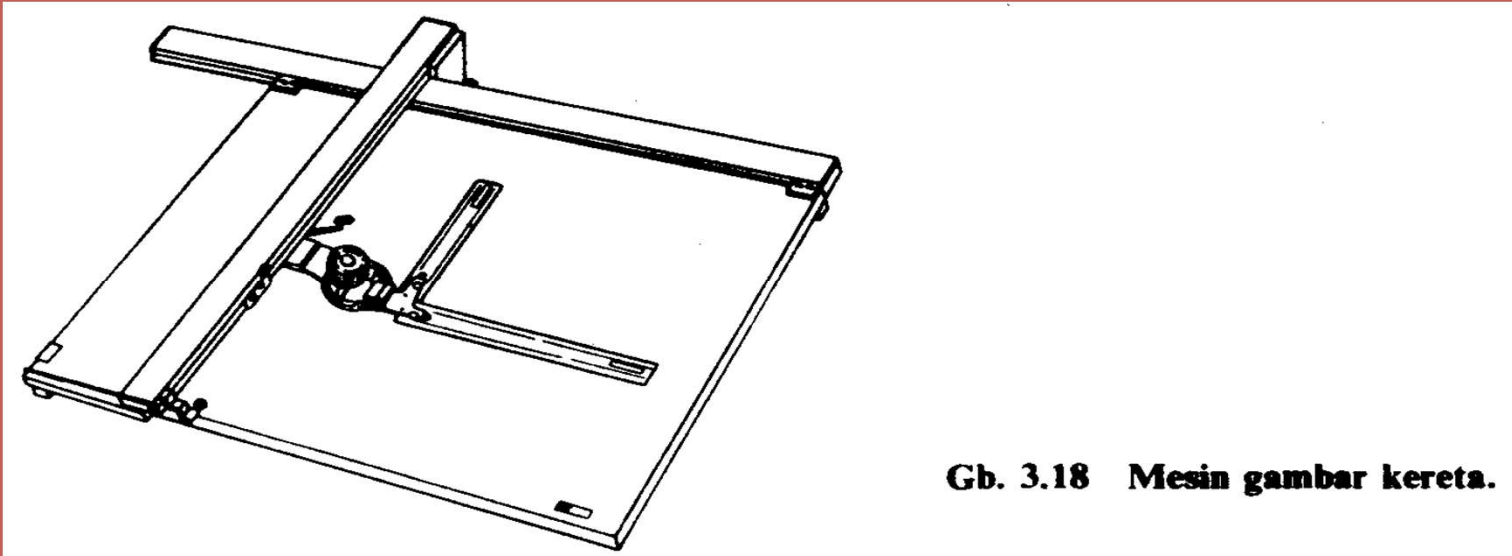

Gb. 3.18 Mesin gambar kereta.

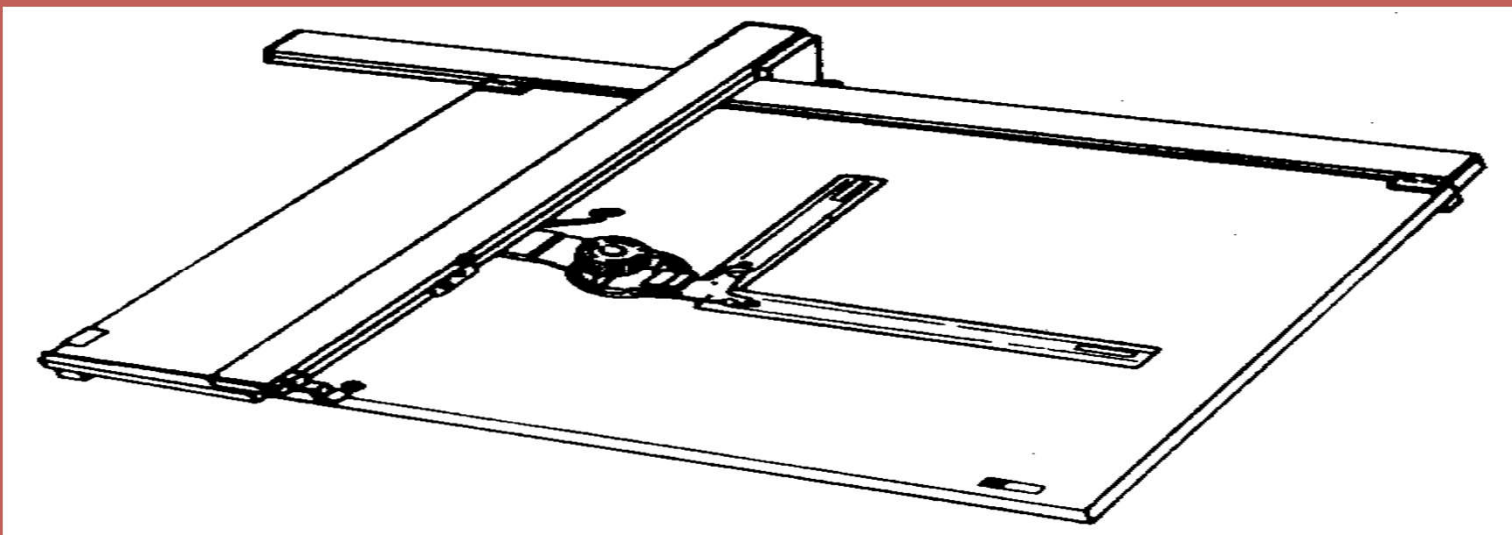

PERALATAN MENGGAMBAR

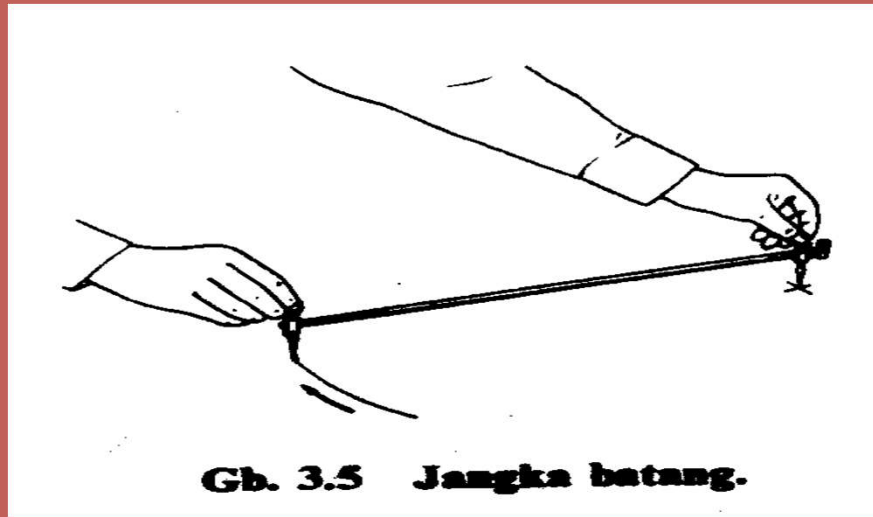
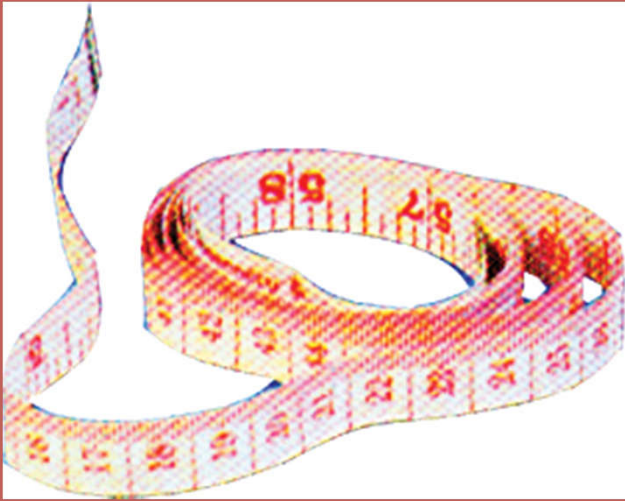

Gb. 3.5 Jangka batang.

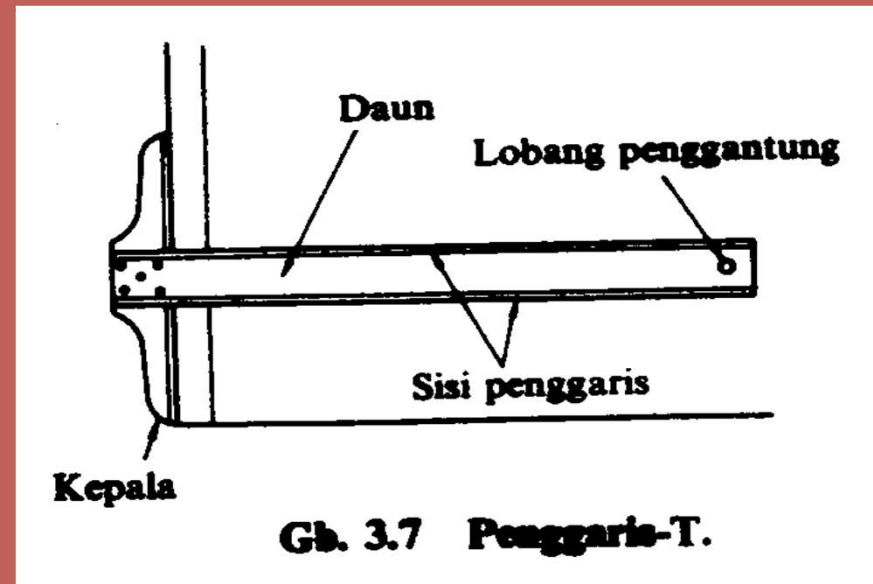
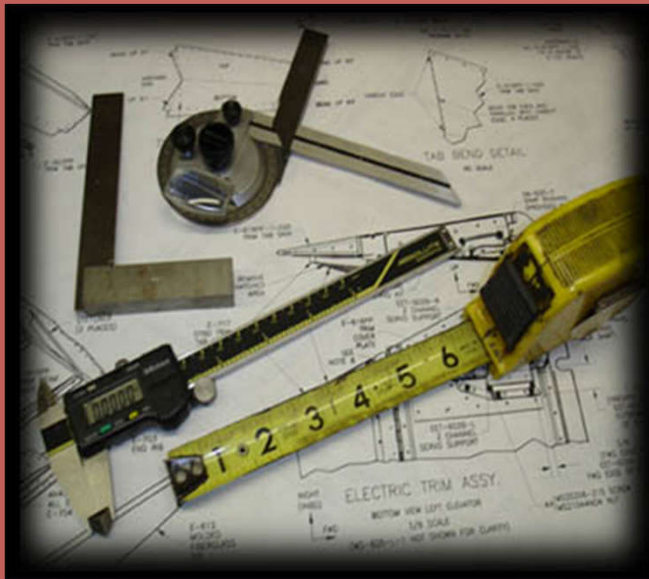

Gb. 3.7 Penggaris-T.

PERALATAN MENGGAMBAR

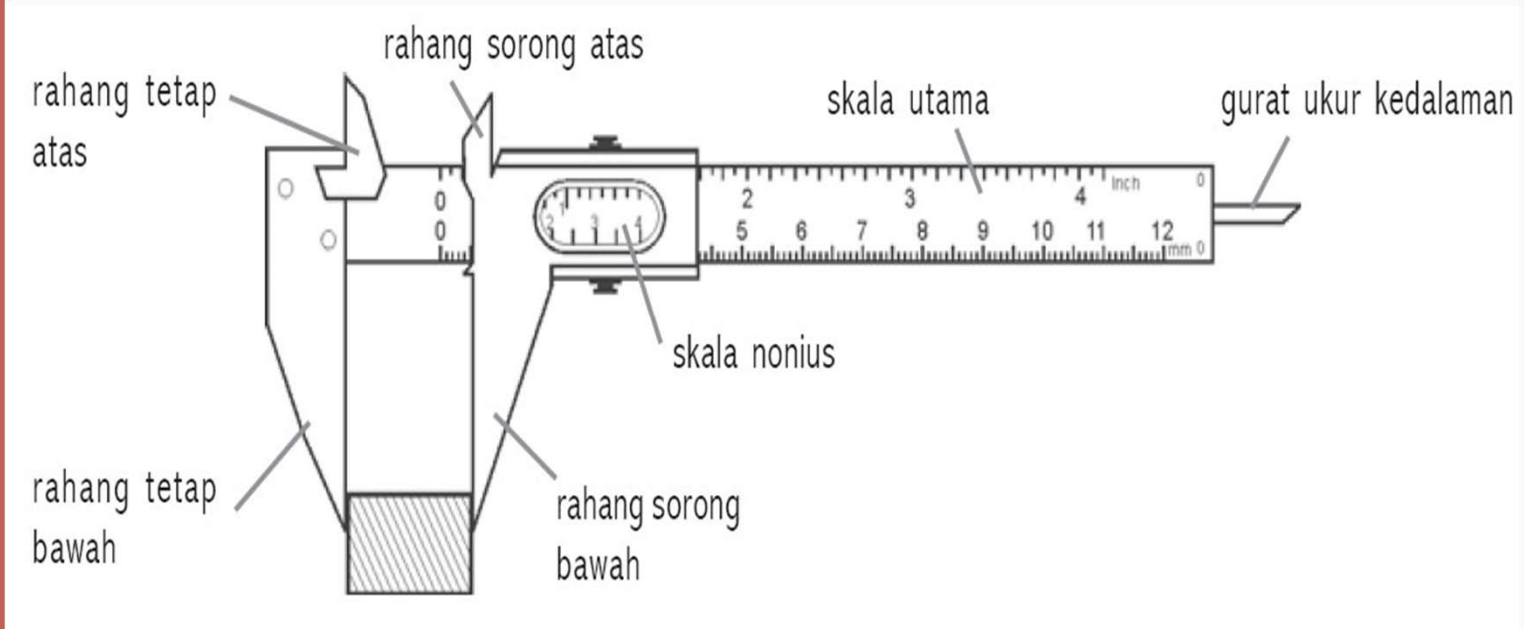
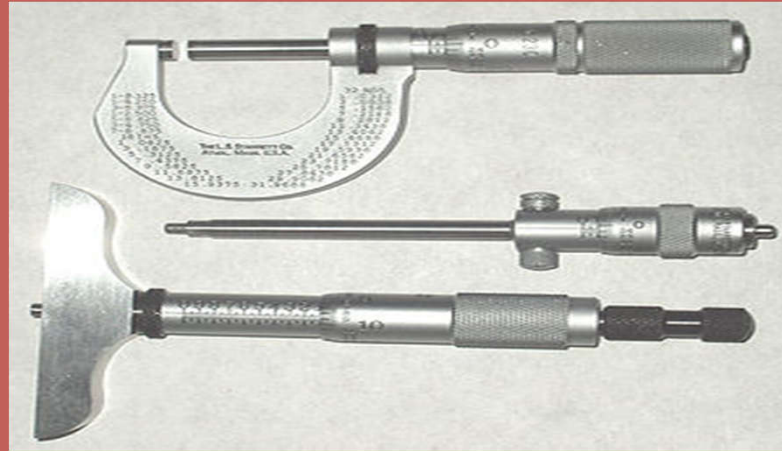
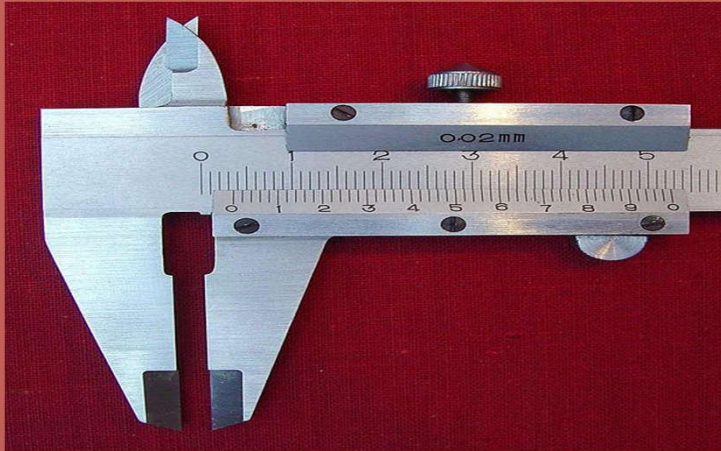

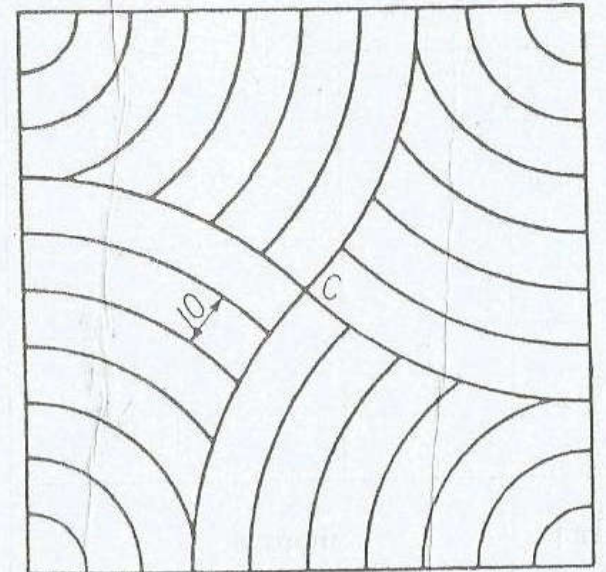
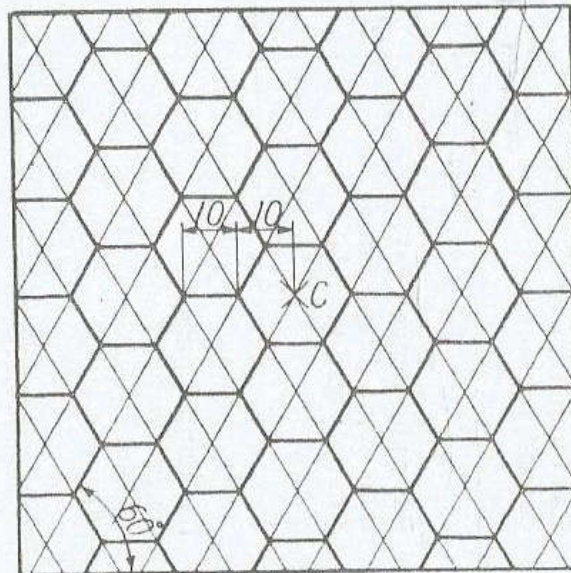
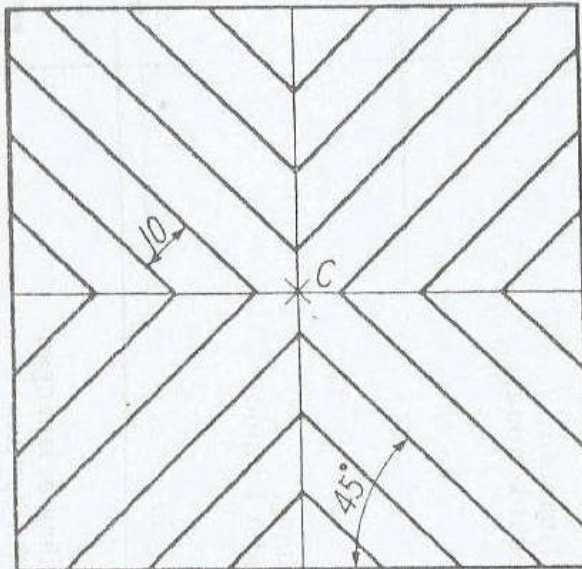
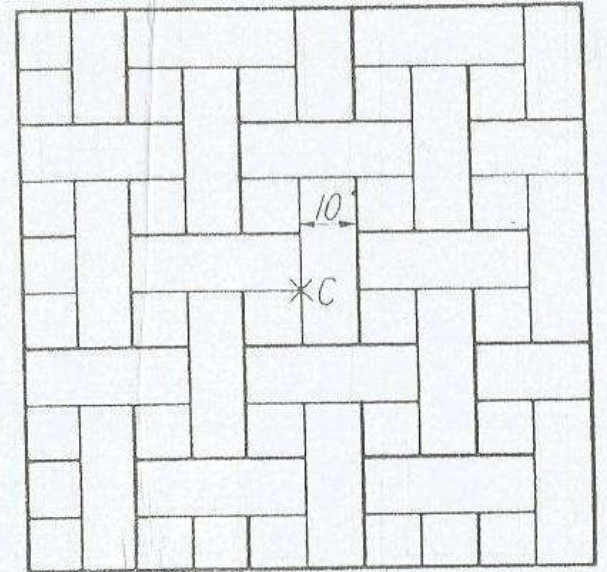
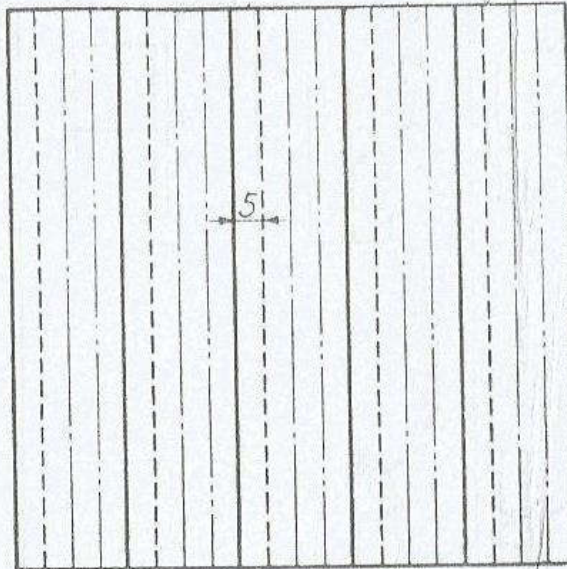
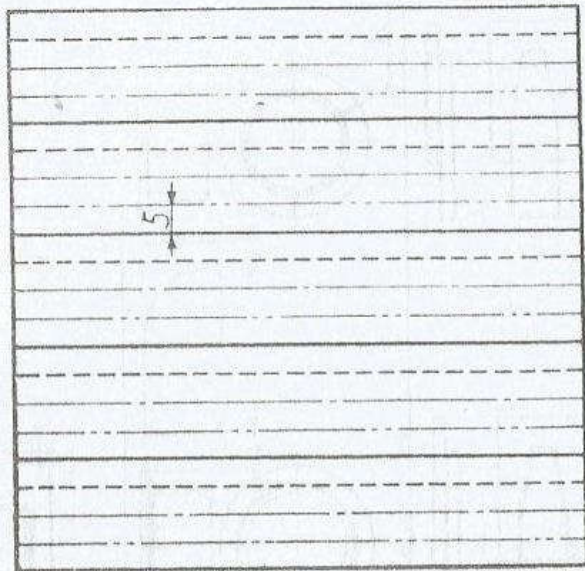

Tugas -2 Macam-Macam Garis

DAFTAR NILAI

SEMESTER GANJIL REGULER TAHUN 2020/2021

Program Studi : Teknik Mesin S1

Matakuliah : Gambar Mesin 1

Kelas / Peserta : A

Perkuliahan : Kampus ISTN Bumi Srengseng Indah

Dosen : Rudi Saputra, Ir. MT

Hal. 1/1

No	NIM	N A M A	ABSEN	TUGAS	UTS	UAS	MODEL	PRESENTASI	NA	HURUF
			10%	20%	30%	40%	0%	0%		
1	16210001	Mochamad Ichean	94	0	70	0	0	0	0	
2	16210016	Bayu Nur Prasetyo	100	90	70	70	0	0	77	A-
3	20210001	Andi Jullianto	100	40	75	65	0	0	66.5	B-
4	20210002	Hafizh Adiya Pratama	100	100	70	70	0	0	79	A-
5	20210003	Ahmad Zakky Annawawi	94	0	0	0	0	0	0	
6	20210004	E. Rayhan Danang Oktavian	94	0	70	0	0	0	0	
7	20210005	Tedy Kueuma Putra	81	0	70	0	0	0	0	

Rekapitulasi Nilai							
A	0	B+	0	C+	0	D+	0
A-	2	B	0	C	0	D	0
		B-	1	C-	0	E	0

Jakarta, 1 February 2021

Dosen Pengajar



Rudi Saputra, Ir. MT