



YAYASAN PERGURUAN CIKINI  
INSTITUT SAINS DAN TEKNOLOGI NASIONAL

Jl. Moh. Kahfi II, Bhumi Srengseng Indah, Jagakarsa, Jakarta Selatan 12640  
Telp. 021-7270090 (hunting), Fax. 021-7866955, hp: 081291030024  
Email : humas@istn.ac.id Website : www.istn.ac.id

**SURAT PENUGASAN TENAGA PENDIDIK**

Nomor : 281 / 03.1 – G / IX / 2023

SEMESTER **GANJIL**, TAHUN AKADEMIK 2023 / 2024

Nama	: Ariman,ST,MT	Status Pegawai	: Edukatif Tetap / Tidak Tetap			
NIK	: 1961010	Program Studi	: Teknik Elektro			
Jabatan Akademik	: <b>Asisten Ahli</b>					
Bidang	Perincian Kegiatan	Tempat	Jam/ Minggu	Kinerja (sks)	Keterangan	
<b>I PENDIDIKAN Dan PENGAJARAN</b>	<b>MENGAJAR DI KELAS ( KULIAH / RESPONSI DAN LABORATORIUM )</b>					
	1. Fisika Terapan ( Kls A )			2	Selasa, 08.00-09.40	
	2. Ilmu Bahan Listrik ( Kls A )			2	Rabu, 08.00-09.40	
	3. K3 & Teknik Lingkungan ( Kls A )			2	Rabu, 10.00-11.40	
	4. Mekatronika ( Kls A )			2	Selasa, 10.00-11.40	
	5. Sistem Cerdas ( Kls A )			2	Selasa, 13.00-15.30	
	6. Sistem Kendali Adaptif (KIS A)			2	Senin, 08.00-09.40	
	7. Fisika Terapan (K)			2	Sabtu, 10.00- 11.40	
	8. Ilmu Bahan Listrik (K)			2	Kamis, 19.00-20.40	
	9.				,	
	10.				,	
	11.				,	
	12.				,	
	13.				,	
	14.				,	
	15.				,	
	16.				,	
	17. Membimbing Skripsi / Tugas Akhir				1	
18. Menguji Skripsi / Tugas Akhir				1		
<b>II PENELITIAN</b>	1. Penelitian Ilmiah			1		
	2. Penulisan Karya Ilmiah			1		
	3. Penulisan Diktat Kuliah			1		
	4. Menerjemahkan Buku					
	5. Pembuatan Rancangan Teknologi					
	6. Pembuatan Rancangan & Karya Pertunjukan					
<b>III PENGABDIAN DAN MASYARAKAT</b>	1. Menduduki Jabatan di Pemerintahan					
	2. Pengembangan Hasil Pendidikan Dan Penelitian					
	3. Memberikan Penyuluhan/Pelatihan/Ceramah pada masyarakat					
	4. Memberikan Pelayanan Kepada Masyarakat Umum				1	
	5. Menulis Karya Pengabdian Pada Masyarakat yang tidak dipublikasikan				1	
	6. Komersial / Kesepakatan					
<b>IV UNSUR-UNSUR PENUNJANG</b>	1. Jabatan Struktural					
	2. Penasehat Akademik			1		
	3. Berperan serta aktif dalam pertemuan ilmiah / seminar					
	4. Pengembangan program kuliah / Kelompok Ilmu Elektro					
	5. Menjadi anggota panitia / Badan pada suatu Perguruan Tinggi					
	6. Menjadi anggota Badan Lembaga Pemerintah					
	7. Menjadi Anggota Organisasi Profesi					
	8. Mewakili PT / Lembaga Pemerintah duduk dalam Panitia antar Lembaga					
	9. Menjadi Anggota Delegasi Nasional ke Parlemen – Parlemen Internasional					
Jumlah Total				<b>24</b>		

Kepada yang bersangkutan akan diberikan gaji / honorarium sesuai dengan peraturan penggajian yang berlaku di Institut Sains dan Teknologi Nasional  
Penugasan ini berlaku dari tanggal **25 September 2023** sampai dengan tanggal **29 Februari 2024**.

Jakarta, 25 September 2023  
Dekan,  
  
(Dr. Musfirah Cahya F.T.S.Si., M.Si.)

**Tembusan :**

1. Direktur Akademik – ISTN
2. Direktur Non Akademik - ISTN
3. Ka. Biro Sumber Daya Manusia - ISTN
4. Kepala Program Studi Fak. ....



## Calculation Analysis of Wire Feeder Power Delivery Efficiency on LineX – Y, Middle Java

Edy Supriyadi<sup>1\*</sup>, Iriandi Ilyas<sup>2</sup>, Ariman<sup>3</sup>, Raihan Shodiq<sup>4</sup>

<sup>1</sup>Institut Sains Dan Teknologi Nasional, Jakarta, Indonesia, e-mail: [edy\\_syadi@istn.ac.id](mailto:edy_syadi@istn.ac.id)

<sup>2</sup>Institut Sains Dan Teknologi Nasional, Jakarta, Indonesia,

<sup>3</sup>Institut Sains Dan Teknologi Nasional, Jakarta, Indonesia,

<sup>4</sup>Institut Sains Dan Teknologi Nasional, Jakarta, Indonesia,

\*Corresponding Author: [edy\\_syadi@istn.ac.id](mailto:edy_syadi@istn.ac.id)

**Abstract:** The electric train (KRL) is a form of application of scientific and technological developments in the field of transportation so that KRL can replace modes of transportation that use coal or use diesel. Currently electric trains in Indonesia are one of the modes of transportation that are most widely used every day for activities ranging from transportation for schools and colleges to transportation used to go to work and other important activities. Every year electric train passengers in Indonesia are increasing, starting from 100 thousand passengers per day until it is predicted to be 1 million passengers per day. The capacity of the Purwosari Traction Substation (GT) can be categorized as sufficient, with the difference between the specifications of the power capacity and the calculated capacity of only 57.9%. On the Purwosari – Solo Balapan route, the cable type resistance was 0.000167  $\Omega$ /m, from this type of resistance to the resistance calculated from usage, a difference of around 20.9%. As for the Feeder Wire type resistance, the cable specification limit with the calculation is still below the maximum limit so it is still feasible to use. Because the specification limit and the calculation results are around 99.654% of the limit at 20°C.

**Keyword:** Traction Substation, KRL, Overflow Network, Feeder Wire, Electrical resistivity.

### INTRODUCTION

In 2023, in the 6.3 Solo Resort area which has 3 traction substations, namely the Gawok traction substation, Purwosari traction substation and Solojebres traction substation, it is necessary to analyze the calculation of the Feeder Wire Power Distribution Efficiency, whether it is still efficient. For the purpose of the analysis, it is necessary to analyze the calculation of feeder cable power resistance from DS (Disconnecting Switch) to cross KRL by using the calculation method of power consumption based on headway time. The results of this analysis will produce outputs in the form of evaluating the power capacity of existing substations, while to analyze the power capacity of existing substations, using the

calculation method for DC electrification systems.

**LITERATURE REVIEW**

**System on the Upstream Electricity Network**

Seen in Figure 1 above shows the upper flow electricity network system. The following parts - parts that exist in the upper flow electrical network system:

1. Messenger wire
2. Feeder Wire
3. Trolley Wire
4. Hanger Wire

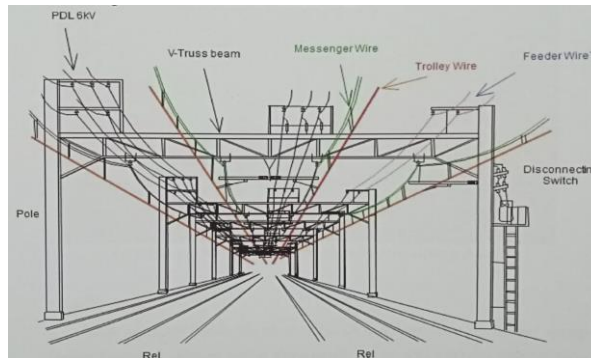

(Source: Simple Catenary Type Upstream Electricity in PPI-Madiun Campus Area F. W. Kurniawan)

**Figure 1. System on the Upstream Electricity Network**

In Figure 2 shows the power supply system using a two-sided supply system, namely from traction substations A and B supplying power to KRL in parallel. The negative voltage from the rail is applied to the rectifiers of traction substations A and B. In the event of a disturbance that causes the traction substation to be unable to operate, the other traction substation (next to it) can be used to supply power to the KRL on that stretch of road.

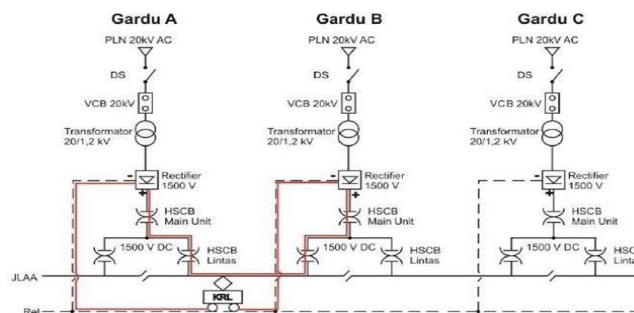

(Source: Simple Catenary Type Upstream Electricity in PPI-Madiun Campus Area, F. W. Kurniawan )

**Figure 2. Traction Substation Two-Sided Supply System.**

**Performance Analysis Calculation Steps**

1. Calculating Electrification Factor Value

The electrification factor value can be calculated using the formula:

$$C_m = 1.7 \sqrt{I_{eff}} \tag{1}$$

Where,

- $C_m$  = Electrification Factor
- $I_{eff}$  = Effective Current, Ampere

2. Calculating Maximum Load in 1 Hour.

Then the maximum load in one hour can be calculated using the formula:

$$P_b = C \times D \times \frac{60}{H} \times N \times R \times \frac{w}{1000} \tag{2}$$

Where,

- $P_b$  = Maximum load in one hour, kW
- $C$  = Series arrangement, set
- $D$  = Traction substation supply distance, km
- $H$  = Headway, hour
- $N$  = Track type, single track or double track
- $R$  = Train electricity consumption ratio, Watt . hour / ton . km
- $w$  = Total weight of the train + passengers, ton

3. Calculating Power Capacity Based on Headway.

Power capacity based on headway denoted by the letters ( $P_h$ ) can be calculated using the formula:

$$P_h = P_b + 1.7 \times \sqrt{I_{eff}} \times \sqrt{P_b} \tag{3}$$

Where,

- $P_h$  = Power capacity based on headway, kW

4. Calculating Power Capacity Based on Maximum Load.

Power capacity based on the maximum current denoted by the symbol ( $P_a$ ) can be calculated using the formula:

$$P_a = 1.5 \text{ kV} \times 2 I_{eff}(I_a) \tag{4}$$

Where,

- $P_a$  = Power capacity based on effective current, kW

5. Calculating Traction Substation Power Capacity Required.

The required traction substation power capacity denoted by the letters ( $P_{gt}$ ) can be calculated using the formula:

$$P_{gt} = \frac{P_h}{3.5} \tag{5}$$

Where,

- $P_{gh}$  = Required traction substation power capacity, kW

6. Calculating Traction Substation Power Capacity.

Calculation of the power capacity of the traction substation can use the formula equation:

$$P = \frac{P_{sr}}{Kt_{20kV}} \times (P_{PLN} - Kt_{6kV})$$

$$A = \frac{P}{1500 V_{DC}} \tag{6}$$

Where,

- $P_a$  = Power, kW
- $A$  = Current, Ampere
- $P_{sr}$  = Silicon Rectifier Power, kW
- $K_r$  = Transformer Capacity, kVA

7. Calculating Percentage Difference between available power and calculated power.

The percentage difference is used to find out how much power is calculated from



the available power and calculation power. The following formula is used to determine the results of the percentage difference:

$$P_t(kW) - P_p(kW) = \Delta P$$

$$\frac{\text{Selisih}(\Delta P)}{P_t(kW)} \times 100\% = \tag{7}$$

Where,

- $P_t$  = Available Power, kW
- $P_p$  = Calculated Power , kW
- $\Delta P$  = Difference Power, kW

### 8. Calculating Barriers Type.

Specific resistance or resistance can be used to see the feasibility of feeder wire. First we find the specific resistance of the cable used with the formula:

$$R_s = \rho \frac{l}{A} \tag{8}$$

Where,

- $R_s$  = Resistance Specific ,  $\Omega$
- $\rho$  = Specific Resistance (Copper:  $1.72 \times 10^{-8}$  )
- $l$  = Conductor Length , m
- $A$  = Conductor Cross-Sectional Area,  $m^2$

The calculation of traction substation resistance can use the following equation:

$$R_p = \frac{P_p}{I^2} \tag{9}$$

Where,

- $R_p$  = Calculation Resistance ,  $\Omega$
- $P_p$  = Calculated Power , kW
- $I$  = Current , Ampere

To find the resistance at a certain temperature. The following formula equation:

$$R_t = R_0[1 + \alpha(t - t_0)]. \tag{10}$$

Where,

- $R_t$  = Resistance at temperature  $t$  ,  $\Omega$
- $R_0$  = Resistance at reference temperature (e.g.  $0^\circ\text{C}$  or  $20^\circ\text{C}$ ),  $\Omega$
- $\alpha$  = Temperature coefficient of specific resistance , $0.00393/^\circ\text{C}$
- $t$  = Temperature to be calculated.  $^\circ\text{C}$
- $t_0$  = Reference temperature , $^\circ\text{C}$

## METHODS

### Research Flowchart

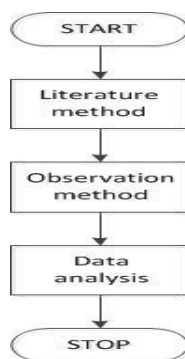

Figure 3. Research flow chart

While the methods used in this research are:

#### 1. Literature Method

The literature method is a way of obtaining data through things or variables in the form of notes, transcripts, books, newspapers, and magazines. The documentation that researchers will use is data related to the feeder wire used in the Electric Railway Overflow (LAA) network.

#### 2. Observation Method

In this method what is done is data collection by direct observation or by direct observation. At this stage the following data were obtained:

- a. Equipment data on the traction substation includes the location of the traction substation, the distance between the traction substation, the specifications of the traction substation at PT. KAI DAOP 6, the data is used to obtain the resistance value.
- b. Data related to the weight of KRL trains, traction motor power requirements and KRL auxiliary equipment, the data is needed to calculate the electrical power requirements of KRL trains.
- c. Single Line Diagram of KRL traction substation

#### 3. Analysis

In this stage, after obtaining the data needed in the research, this data will be analyzed and evaluated to get the desired research results.

## Data Collection

### Procedures

The required parameter measurement is to take data from 3 traction substations namely Gawok traction substation, Purwosari traction substation and Solojebres traction substation. This data is used as observation data for testing the actual substation power capacity performance. After the observation data is processed using the equations discussed, the next step is to take some parameters that will be used for data processing. Data collection was carried out for 2 days for 20 hours, namely in July, the third week of 2023 in accordance with the minimum data collection. In addition, data collection is carried out when the system is in a base load state. Base load is a condition where KRL produces output power in the form of maximum electric power. This is done so that the results of data processing have a value in the same condition so that the results are not ambiguous.

## Calculation

#### 1. Electrification Factor Value.

By taking one of the research samples at the Puwosari Traction Substation (GT PWS)

location, the following calculations are carried out with formula 1 as follows:

$$C_m = 1.7 \sqrt{I_{eff}}$$

$$I_{eff} = 2500$$

$$C_m = 1,7 \sqrt{2500} = 85,00$$

## 2. Maximum Load In 1 Hour.

By taking one of the research samples at the Puwosari Traction Substation (GT PWS) location, the following calculations are carried out with formula 2 as follows:

$$P_b = C \times D \times \frac{60}{H} \times N \times R \times \frac{w}{1000}$$

$$C = 2 \text{ set}$$

$$D = 2.916 \text{ kilo meters (km)}$$

$$H = 6 \text{ hour (h)}$$

$$N = 2 \text{ double track}$$

$$R = 50 \text{ Watt hour / ton . km}$$

$$w = 486.24 \text{ ton}$$

$$P_b = 2 \times 2.916 \text{ km} \times \frac{60}{6 \text{ h}} \times 2 \times 50 \frac{\text{Wh}}{\text{ton.km}} \times \frac{486.24 \text{ ton}}{1000} = 2835.75 \text{ kW}$$

## 3. Power Capacity Based on Headway.

By taking one of the research samples at the Puwosari Traction Substation (GT PWS) location, the following calculations are carried out with formula 3 as follows:

$$P_h = P_b + 1.7 \times \sqrt{I_{eff}} \times \sqrt{P_b}$$

$$P_h = 2835.75 \text{ kW} + (85.00 \times \sqrt{2835.75 \text{ kW}}) = 7362.09 \text{ kW.}$$

## 4. Power Capacity Based on Maximum Load.

By taking one of the research samples at the Puwosari Traction Substation (GT PWS) location, the following calculations are carried out with formula 4 as follows:

$$P_a = 1.5 \text{ kV} \times 2 I_{eff}(I_a)$$

$$P_a = 1.5 \text{ kV} + (2 \times 2.5 \text{ kA} \times (1 - 0.8)) = 6.1 \text{ kW.}$$

## 5. Traction Substation Power Capacity Required.

By taking one of the research samples at the Puwosari Traction Substation (GT PWS) location, the following calculations are carried out with formula 5 as follows:

$$P_{gt} = \frac{P_h}{3.5}$$

$$P_{gt} = (7362.09 \text{ kW} / 3.5) = 2103.45 \text{ kW.}$$

## 6. Traction Substation Power Capacity.

By taking one of the research samples at the Puwosari Traction Substation (GT PWS) location, the following calculations are carried out with formula 6 as follows:

$$P_{sr} = 4000 \text{ kW}$$

$$K_{t20 \text{ kV}} = 4420 \text{ kVA}$$

$$P_{PLN} = 5540 \text{ kVA}$$

$$K_{t6 \text{ kV}} = 200 \text{ kVA}$$

$$P = \frac{P_{sr}}{K_{t20 \text{ kV}}} \times (P_{PLN} - K_{t6 \text{ kV}})$$

$$A = \frac{1500 \text{ V}_{DC}}{4000 \text{ (kW)}}$$

$$P = \frac{4000 \text{ (kW)}}{4420 \text{ (kVA)}} \times (5540 \text{ kVA} - 200 \text{ kVA}) = 4832.57 \text{ kW}$$

$$A = \frac{4832570 \text{ W}}{1500 \text{ V}} = 3221.71 \text{ Ampere}$$

7. Percentage Difference between available power and calculated power.

The percentage difference is used to find out how much power is calculated from the available power and calculation power. The following formula 7 is used to determine the results of the percentage difference:

$$\begin{aligned}
 P_t &= 5000 \text{ kW} \\
 P_p &= 2103.45 \text{ kW} \\
 P_t(kW) - P_p(kW) &= \Delta P \\
 \frac{\text{Selisih}(\Delta P)}{P_t(kW)} \times 100\% &= \\
 \Delta P &= 5000 \text{ (kW)} - 2103.45 \text{ (kW)} = 2896.55 \text{ kW} \\
 \text{in } \Delta P \% &= \frac{2896.55}{5000} \times 100\% = 57.9\%
 \end{aligned}$$

8. Barriers Type.

Specific resistance or resistance can be used to see the feasibility of feeder wire. First we find the specific resistance of the cable used with the formula 8 :

$$\begin{aligned}
 \rho &= 1.72 \times 10^{-8} \\
 l &= 2916 \text{ m} \\
 A &= 0.3 \text{ m}^2 \\
 R_s &= \rho \frac{l}{A} \dots\dots \\
 R_s &= 1.72 \times 10^{-8} \times \frac{2916}{0.3} = 0.000167 \Omega / m
 \end{aligned}$$

The calculation of obstacles on the Purwosari - Solobalapan crossing path with the formula 9:

$$\begin{aligned}
 P_p &= 2103.45 \text{ kW} \\
 I &= 3221.71 \text{ Ampere} \\
 R_p &= \frac{P_p}{I^2} \\
 R_p &= \frac{2103.45}{(3221.71)^2} = 0.000202 \Omega
 \end{aligned}$$

The calculation of the difference between the specified limit and the calculated obstacle is as follows:

$$\begin{aligned}
 R_s(\Omega) - R_p(\Omega) &= \Delta R = 0.000167 \Omega - 0.000202 \Omega = 0.000035 \Omega \\
 \frac{\text{Selisih}(\Delta R)}{R_s(\Omega)} \times 100\% &= \frac{0.000035 \Omega}{0.000167 \Omega} \times 100\% = 20.9\%
 \end{aligned}$$

Here is the calculation for a temperature of 20°:

- Calculating the resistance value of Purwosari feeder wire,

$$R_p = \frac{2103.45}{(3221.71)^2} = 0.000202 \Omega$$

- Calculating resistance at 20°C,

$$R_t = 0.000202 \Omega [1 + 0.00393 / ^\circ\text{C} (32 - 20)] = 0.000211 \Omega$$

Here is the calculation resistance limit specification for a temperature of 20°:

- Calculating resistance limit specification at 20°C,

$$R_t = 0.0611 \Omega [1 + 0.00173 / ^\circ\text{C} (32 - 20)] = 0.060888 \Omega$$



## RESULT AND DISCUSSION

### Calculation Result of Resistance to feeder cable

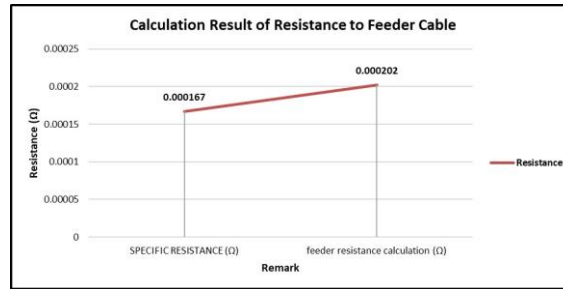

Figure 4. Calculation Result of Resistance to feeder cable

Figure 4 shows the obstacle specification data used and the data that calculates the obstacles on the Purwosari - Solobalapan crossing line.

### Calculation Result of Resistance to feeder cable at 0.000202 Ω

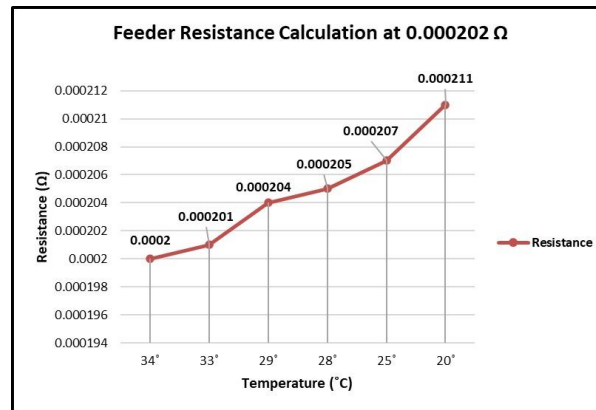

Figure 5. Feeder Resistance Calculation at 0.000202 Ω

Seen in Figure 5, when the temperature drops, the resistance to the feeder wire will increase in resistance. The data from the calculation results can further affect the quality of the feeder wire to decrease. So that the life of the feeder wire will quickly decrease. It can be seen that at temperatures of 34 ° C and 33 ° C there is an increase in resistance of 0.000001 Ω. So it is concluded that every temperature drop of 1 ° C will increase by 0.000001 Ω or about 0.001%.

### Percentage Difference of Calculation with Feeder Wire Barriers on Purwosari - Solo Balapan Crossing

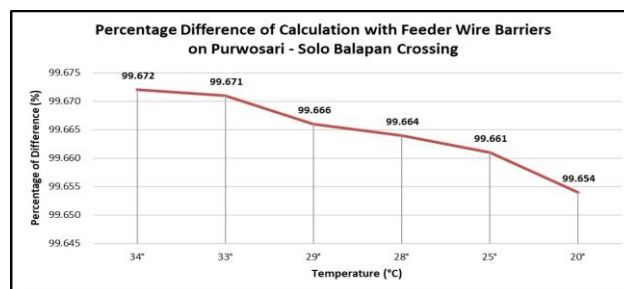

Figure 6. Percentage Difference of Calculation with Feeder Wire Barriers on Purwosari - Solo Balapan Crossing

From Figure 6, it can be seen that the percentage between the maximum limit of cable resistance is  $0.0611 \Omega$  with cable resistance at a temperature of  $20 \text{ }^\circ\text{C}$ , obtained by 99.654%.

## CONCLUSION

From the analysis and calculation that has been done on the efficiency of Feeder Wire Power Distribution on the Purwosari - Solo Balapan Line, it can be concluded that:

1. The calculation results at a type of cable resistance on the Purwosari - Solo Balapan line with a value of  $0.000167 \Omega/\text{m}$ .
2. The results of the power calculation obtained the resistance value is  $0.000202 \Omega$ .
3. The difference between the cable type resistance and the resistance calculated from the power amounts to  $0.000035 \Omega$  or 20.9%.
4. The calculation results at a temperature of  $20 \text{ }^\circ\text{C}$  obtained the result of its type of resistance of  $0.000211 \Omega$ .
5. Max limit. the type of cable resistance is  $0.0611 \Omega$ .
6. After analyzing the calculation of the feeder wire power efficiency on the Purwosari - Solo Balapan line, it is still categorized as feasible. Because the difference between the specifications of the resistance limit on the feeder wire with a calculation at a temperature of  $20 \text{ }^\circ\text{C}$  is  $0.060889 \Omega$  or around 99.654% of the specified limit

## REFERENCES

- Dugan, Roger. C and Mc Granaghan, Mark.F. Electrical Power System Quality (2003). New York: McGraw-Hill, pp 93-120, 2003.
- Marlock, E. K. (1985). Introduction to Transportation Engineering and Planning , Jakarta: Erlangga.
- Rahadian Fikri, Andri. (2013). Maintenance of the Upflow Electricity Network System at PT KAI. Laporan Kerja Praktik Kerja Lapangan Teknik Elektro Politeknik Negeri Jakarta.
- F. W. Kurniawan (2020), "Simple Catenary Type Upstream Electricity in PPI-Madiun Campus Area,"pp. 23–24, 2020.
- Ida Widiastuti, Dedi Nugroho (2020), " Voltage Drop Analysis on Feeder K3 Kudus Substation ", Laporan Penelitian Program Studi Teknik Elektro Universitas Islam Sultan Agung Semarang.
- Directorate of Railway Infrastructure Monitoring Report on Performance Outcomes for the Third Quarter of 2021.